

Instruction Manual

Model D100 OxyProbe[®] Series

QUICK GUIDE

- Calibration
Chapter 4
- Troubleshooting
Chapter 5
- Installation and
Maintenance
Chapter 7

P18060 7/2003

Measurement and Control Products for Science and Industry
19 Thomas, Irvine, California 92618 USA

Phone: 949.829.5555 Toll-Free: 800.288.2833 Fax: 949.829.5560

E-Mail: sales@broadleyjames.com Website: broadleyjames.com



ESSENTIAL INSTRUCTIONS

READ THIS PAGE BEFORE PROCEEDING!

This product has been designed, manufactured, and tested to meet many national and international standards. Because these sensors are sophisticated technical products, proper installation, use, and maintenance ensures they continue to operate within their normal specifications. The following instructions are provided for integration into your safety program when installing, using, and maintaining these products. Failure to follow the proper instructions may cause any one of the following situations to occur: Loss of life; personal injury; property damage; damage to this sensor and warranty invalidation.

- Read all instructions prior to installing, operating, and servicing the product. If this instruction manual is not the correct manual, telephone (949) 829-5555 and the requested manual will be provided. Save this manual for future reference.
- If you do not understand any of the instructions, contact Broadley-James for clarification.
- Follow all warnings, cautions, and instructions marked on and supplied with the product.
- Inform and educate your personnel in the proper installation, operation, and maintenance of the product.
- Install your equipment as specified in the installation instructions of the appropriate instruction manual and per applicable local and national codes.
- To ensure proper performance, use qualified personnel to install, operate, update, calibrate, and maintain the product.
- When replacement parts are required, ensure that qualified people use replacement parts specified by Broadley-James. Unauthorized parts and procedures can affect the product's performance and place the safe operation of your process at risk. Look alike substitutions may result in improper operation.

Broadley-James Corporation

19 Thomas

Irvine, CA 92618 USA

Tel: (949) 829-5555 (800) 288-2833



OxyProbe® is a registered trademark of Broadley Technologies



Contents

Chapter 1: TECHNICAL DATA	1-1
1.1 Product Specifications	1-1
1.2 Model Identification	1-2
Chapter 2: OXYPROBE® FEATURES	2-1
2.1 Sensor Construction	2-1
Chapter 3: PREPARATION	3-1
3.1 Sensor	3-1
3.2 Sensor Cable	3-5
3.3 Transmitter	3-8
3.4 Remote Recording & Control Devices	3-8
Chapter 4: CALIBRATION	4-1
4.1 Calibration Comments	4-1
4.2 Transmitter Zero Point	4-1
4.3 Sensor Zero Point	4-1
4.4 Calibration: Air Calibration	4-1
4.5 Measurement with Temperature Compensation	4-1
4.6 Calibration: % of Saturation	4-1
4.7 Calibration: mg O ₂ / L	4-2
Chapter 5: FUNCTIONAL CHECK / MAINTENANCE / TROUBLESHOOTING	5-1
5.1 Functional Check of Transmitter	5-1
5.2 Functional Check of DO Sensor	5-1
5.3 Replacement of Membrane Cartridge	5-1
5.4 Troubleshooting	5-2
Chapter 6: EFFECTS ON OXYGEN SENSOR PERFORMANCE	6-1
6.1 Flow Dependence	6-1
6.2 Oxygen Partial Pressure vs. Oxygen Concentration	6-1
Chapter 7: SENSOR INSTALLATION & MAINTENANCE	7-1
7.1 Insertion of the OxyProbe D.O. Sensors	7-1
7.2 Preventative Maintenance	7-1
Chapter 8: REPLACEMENT AND SPARE PARTS	8-1
Chapter 9: RETURN OF MATERIALS	9-1
Chapter 10: WARRANTY	10-1



Contents—Figures

Figure	Title	Page
1	Principle Sensor Components	2-1
2	OxyProbe® Protective Cap Removal	3-1
3	Membrane Cartridge Refill	3-2
4	Membrane Cartridge Installation	3-3
5	Sensor Polarization	3-4
6	OxyProbe® Sensor Cables	3-5
7	AX-5000 Cable Connection to Sensor	3-6
8	AX-5100 Cable Connection to Sensor	3-7
9	Head Plate Installation/Pg 13.5 Threads	7-2
10	Head Plate Installation/Compression Fitting	7-3
11	25 mm side Port with Retractable 797 Housing	7-4
12	D100 and D105 OxyProbe® Exploded View	8-2
13	D140 and D145 OxyProbe Exploded View	8-4
Tables		
1	Solubility of air-saturated deionized water at 760 mm Hg	4-2



Chapter 1: Technical Data

1.1 Product Specifications

Sensor body:	316L stainless steel
Membrane:	Teflon / silicone (steel-mesh reinforced)
Membrane cartridge:	316L stainless steel
Cathode:	Platinum (Pt)
Anode:	Silver (Ag)
Electrolyte:	KOH / KCl solution, pH 13
Response time:	98% of readout in
@25°C	60 seconds
@37°C	20 seconds
Stability:	In water, under constant pressure and at a constant temperature drift amounts to less than 2% per week
Flow dependence:	Readings in stirred and unstirred solutions differ by approximately, 3 – 5 %.
Polarization voltage:	675 mV
Electrode current in ambient air:	Approximately 60×10^{-9} amps
Electrode current in N ₂ :	< 1% of current in ambient air
Temperature coefficient of membrane at constant O ₂ partial pressure:	Approximately 2.3% / K at 25°C
Temperature range:	Operation: 0 – 80°C Sterilization: maximum 130°C
Temperature compensation:	Automatic with built-in thermistor, 22KΩ @ 25°C
Linearity:	< 0.3% of readout
Maximum pressure:	58 psig, 4 bar (atm)
Cable connection:	Standard 4-pin
Wetted materials:	All metal parts in contact with sample solution are made of 316L stainless steel. Wetted surface of membrane is silicone.
O-ring seal:	EPDM



1.2 Model Identification

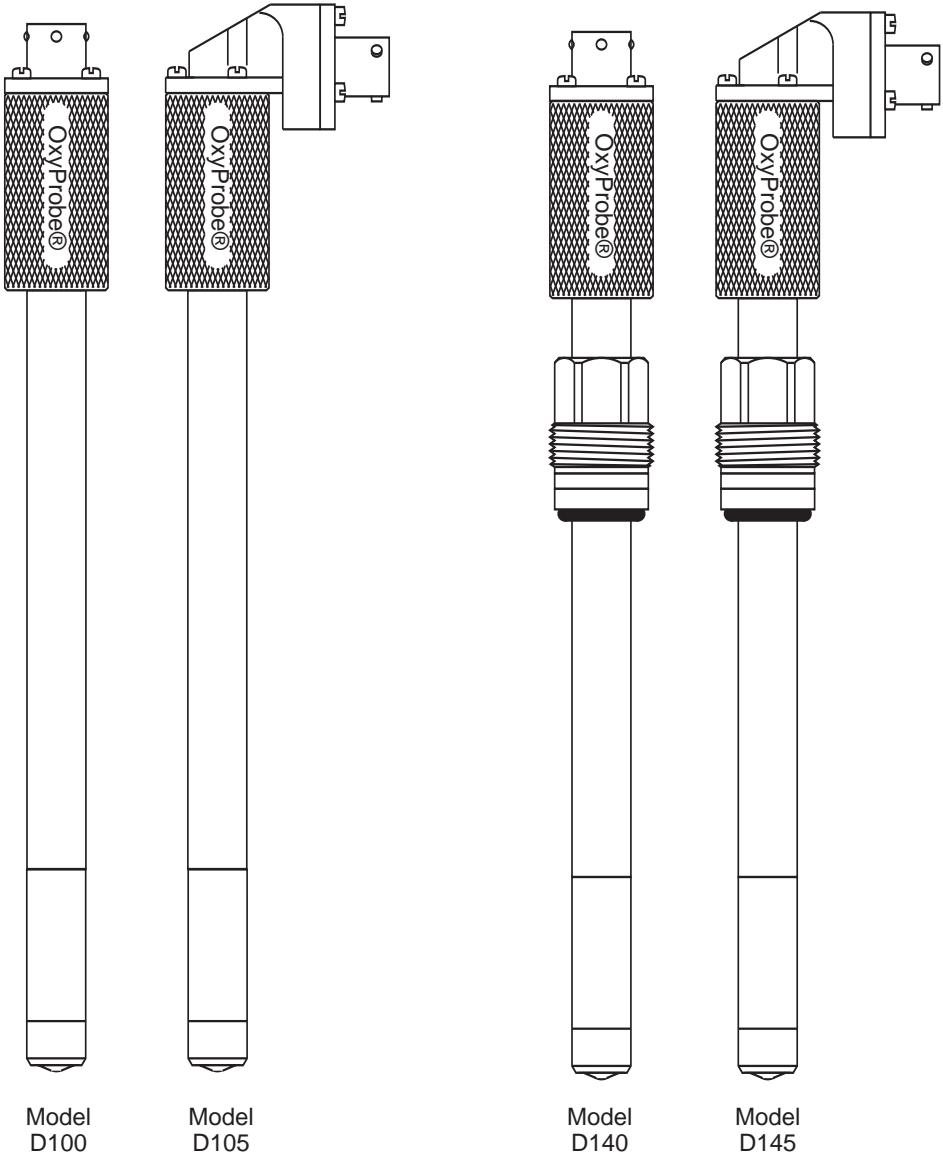

Chapter 2: OxyProbe Features

2.1 Sensor Construction

The principle components of the oxygen sensor are shown in Figure 1. All parts are made of heat resistant materials.

Figure 1

Principle Sensor Components

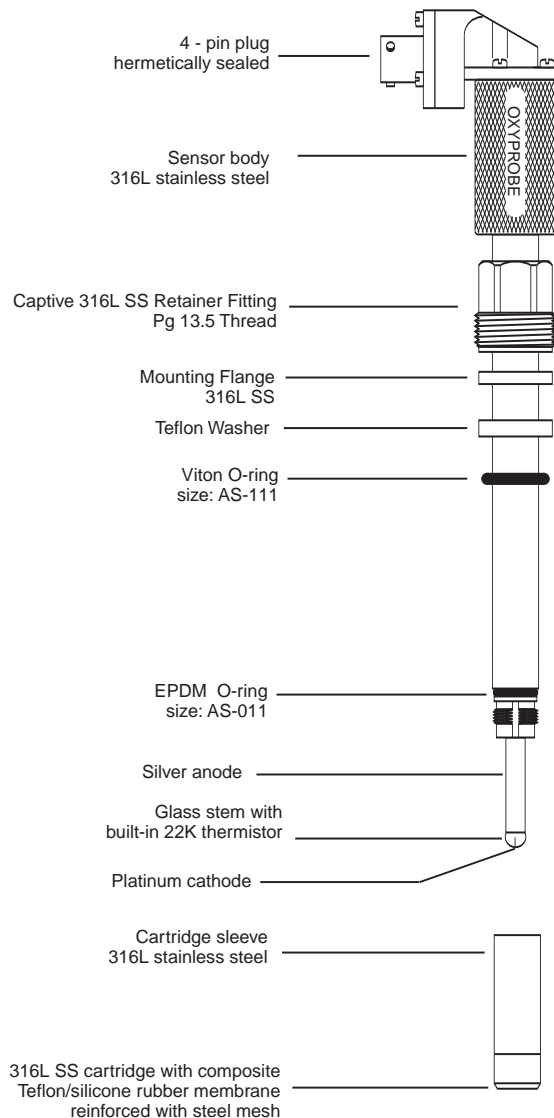

The sensing element is comprised of a glass tube sealed at one end with a fused platinum wire. This sealed end is ground to a precise hemispherical curve. Since the geometrical configuration and roughness of the ground surface have an important effect on sensor performance, no attempt should be made to modify them. A silver anode tube covers the large annular surface of the glass tube. A thermistor for the temperature compensation of sensor current is also incorporated within the glass tube. The tube assembly in turn is mounted and sealed into a stainless steel threaded holder. This is the anode/cathode assembly.

The membrane cartridge, when filled with electrolyte, is placed over the anode/cathode assembly and threaded onto the stainless steel body. The membrane cartridge is sealed at the lower end with a fixed, reinforced, gas-permeable membrane, and is surrounded by a stainless steel sleeve. This seals the cartridge to the sensor body by means of a precision tolerance o-ring seal.

When fully seated, the cartridge sleeve properly positions the tip of the cathode with respect to the inner membrane surface. At the same time optimum pressure of the gas-permeable membrane against the cathode is obtained.

IMPORTANT: EVEN AFTER ASSEMBLY, THE ANODE/CATHODE ASSEMBLY EXTENDS A SLIGHT DEGREE BEYOND THE ENDCAP THOUGH COVERED BY THE MEMBRANE, IT CAN BE DAMAGED BY PHYSICAL IMPACT.

Chapter 3: Preparation

3.1 Sensor

The sensor is shipped with a removable boot that protects the anode/cathode assembly and membrane cartridge during shipment and during long term storage. A moisture proof dust cap is also provided to protect the 4-pin connector. See Figure 2 for removal procedures for these protective caps.

NOTE: Save the moisture proof dust cap to protect the 4-pin connector during autoclave or out of service conditions.

Begin the sensor preparation by following the step by step procedures as shown in Figures 2 through 5.

After removing the protective caps, as shown in Figure 2, proceed with the MEMBRANE CARTRIDGE REFILL and INSTALLATION instructions as shown in Figure 3 and Figure 4. Observe the cautions regarding handling the electrolyte. Rinse lower portion of sensor in DI water and blot dry.

The final step in the sensor preparation involves the POLARIZATION of the sensor which is accomplished as shown in Figure 5.

Figure 2

OxyProbe® Protective Cap Removal

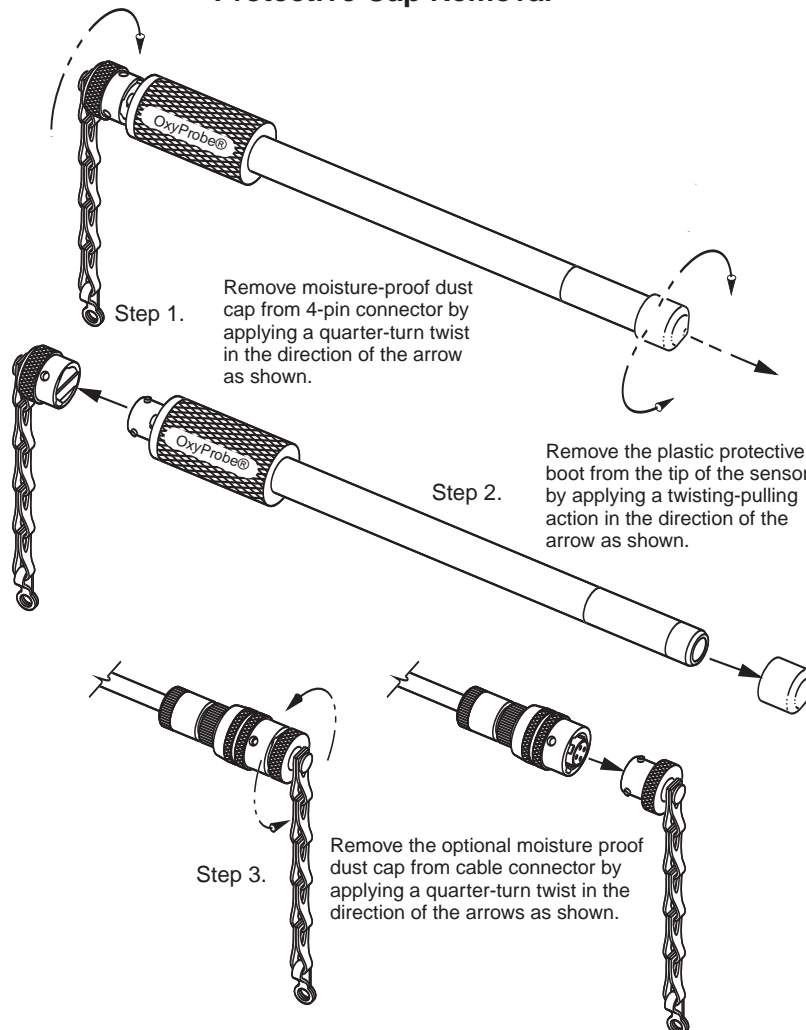
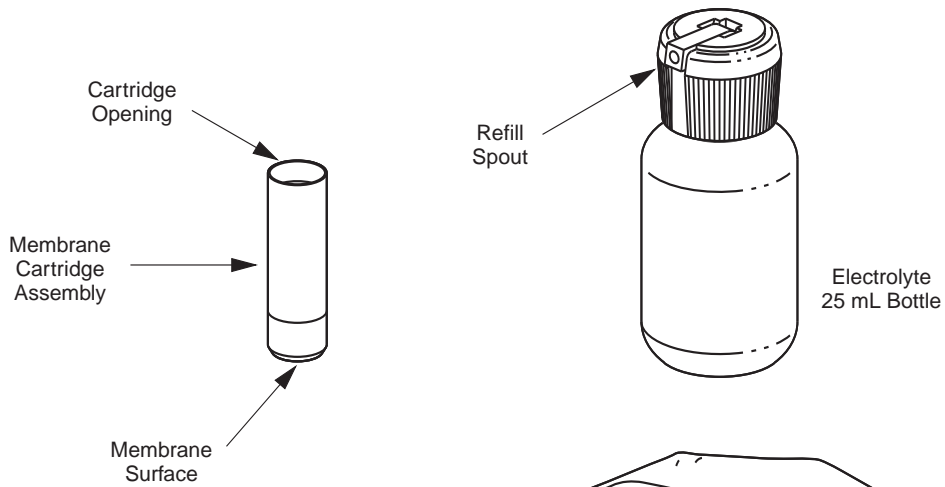
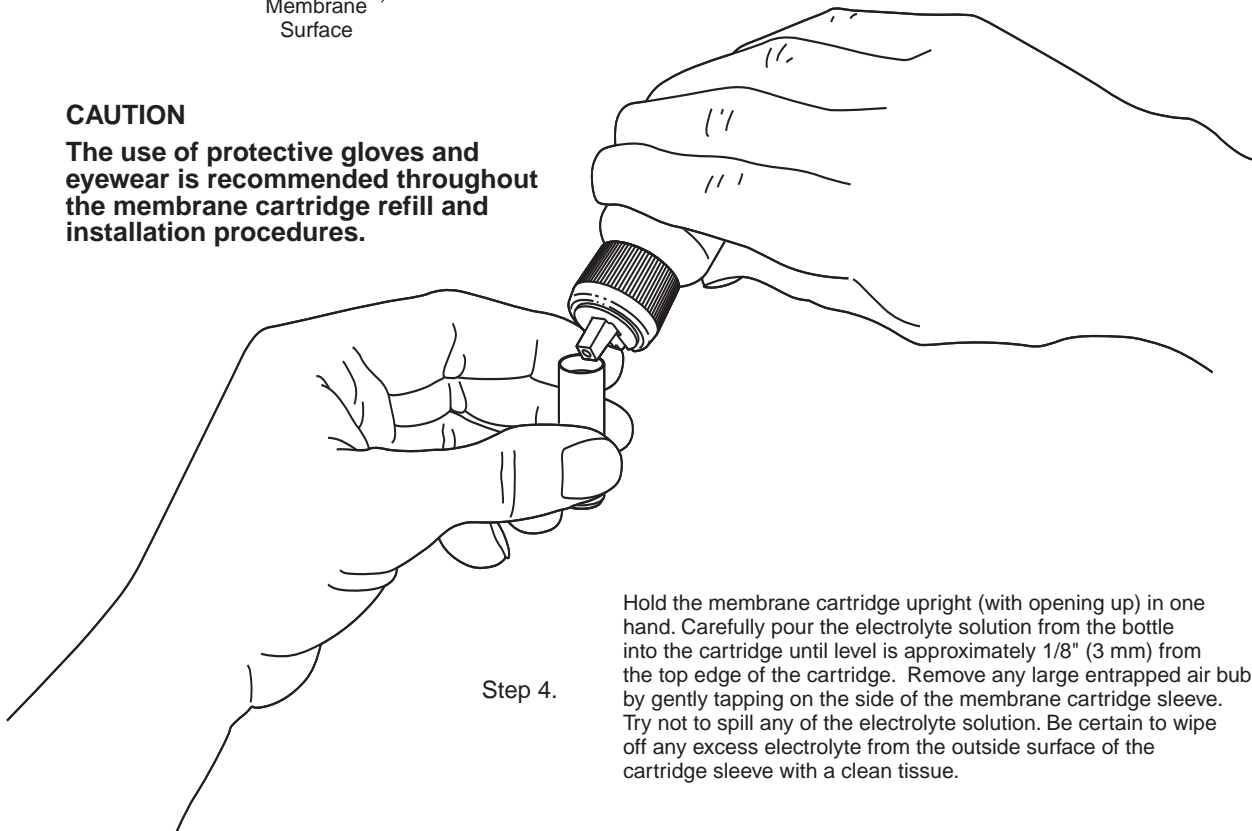

Figure 3

Membrane Cartridge Refill



CAUTION
The use of protective gloves and eyewear is recommended throughout the membrane cartridge refill and installation procedures.



Hold the membrane cartridge upright (with opening up) in one hand. Carefully pour the electrolyte solution from the bottle into the cartridge until level is approximately 1/8" (3 mm) from the top edge of the cartridge. Remove any large entrapped air bubbles by gently tapping on the side of the membrane cartridge sleeve. Try not to spill any of the electrolyte solution. Be certain to wipe off any excess electrolyte from the outside surface of the cartridge sleeve with a clean tissue.



Figure 4

Membrane Cartridge Installation

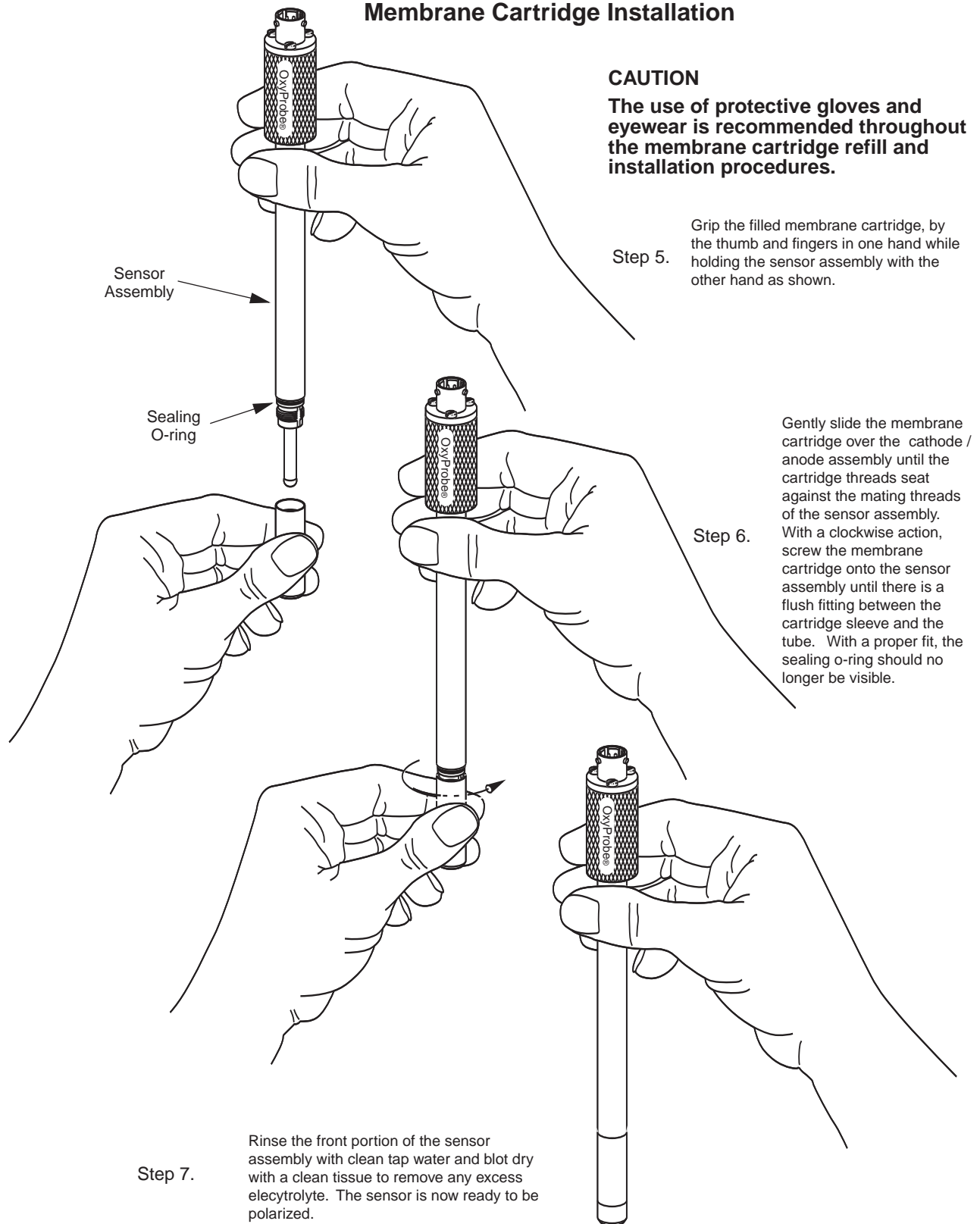
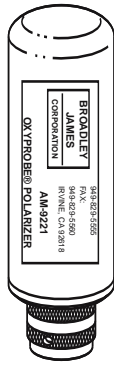

Figure 5

Sensor Polarization



Step 8.

Attach the AM-9221 Polarizing Unit onto the 4-pin connector of the sensor.

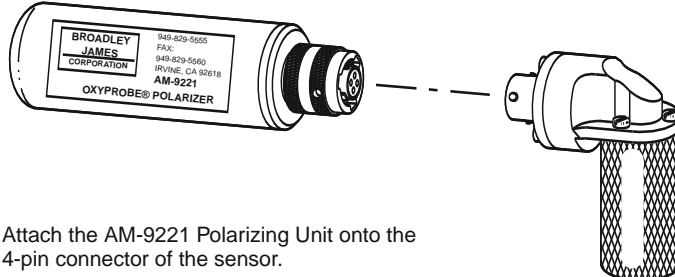

Step 9.

Twist-lock the connector of the AM-9221 Polarizing unit in the direction of the arrow as shown. Permit 6-8 hours for complete polarization.

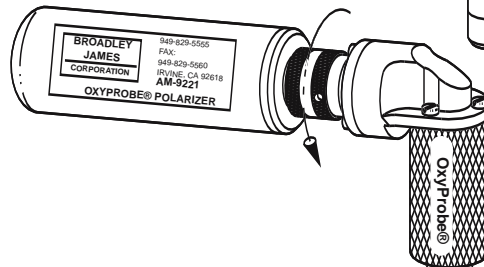
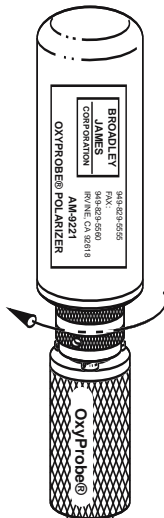

NOTE: SENSOR POLARIZATION MAY ALSO BE ACHIEVED BY CONNECTING THE SENSOR TO THE HOST D.O. TRANSMITTER PROVIDED THE INSTRUMENT IS POWERED.



When the D.O. transmitter is switched on, a polarization voltage is applied between the anode and cathode. The sensor current is initially very high, but then falls off exponentially and settles down to steady state after a few hours. Since this polarization period is relatively long, the sensor should be kept connected to a powered transmitter or polarizing unit (Part Number: AM-9221) when not in use. Owing to the very small current flowing through the sensor under these conditions, its life will not be shortened. If for any reason the sensor has to be disconnected (or the transmitter power switched off) for an extended period, it will have to be repolarized before it is ready for further use.

During the polarization period, the sensor current will also fall off even in oxygen-free solutions. For this reason, an excessive zero current (See Section 4.2) may indicate incomplete polarization.

3.2 Sensor Cable

The oxygen sensor cable is provided in two configurations: (1) the AX-5100 with a protective connector boot; or (2) the AX-5000 without the boot. See Figures 6 – 8 for cable to sensor connections and descriptions.

Refer to the wiring diagram of the D.O. transmitter selected for use with the OxyProbe for proper connection of the sensor.

Figure 6

OxyProbe® Sensor Cables

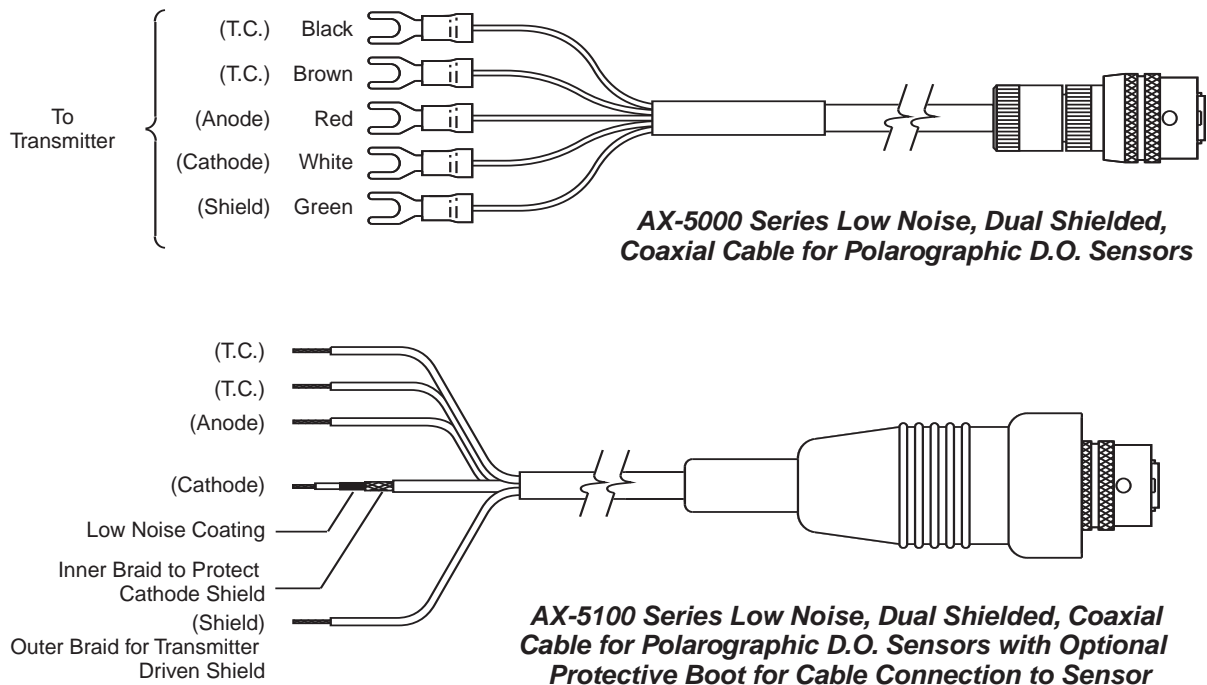
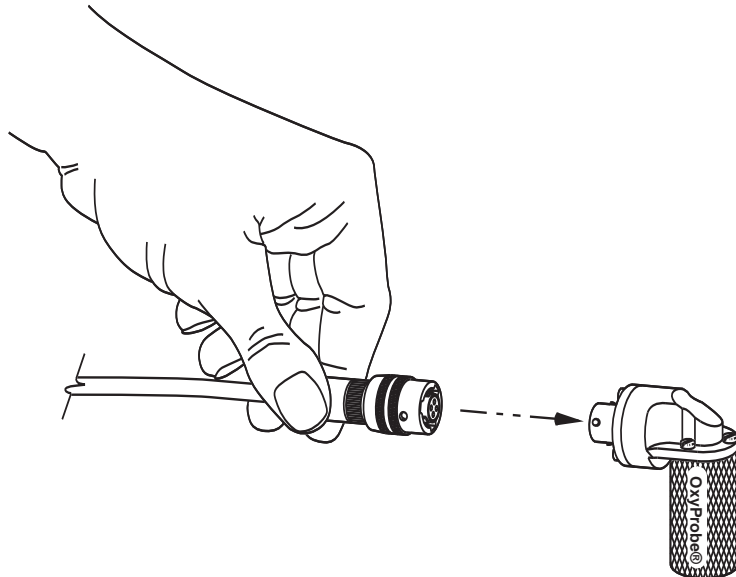

Figure 7

AX-5000 Cable Connection to Sensor

Step 10.

Insert the 4-pin cable connector into the 4-pin connector of the sensor.



Step 11.

Twist-lock the cable connector in the direction of the arrow as shown.

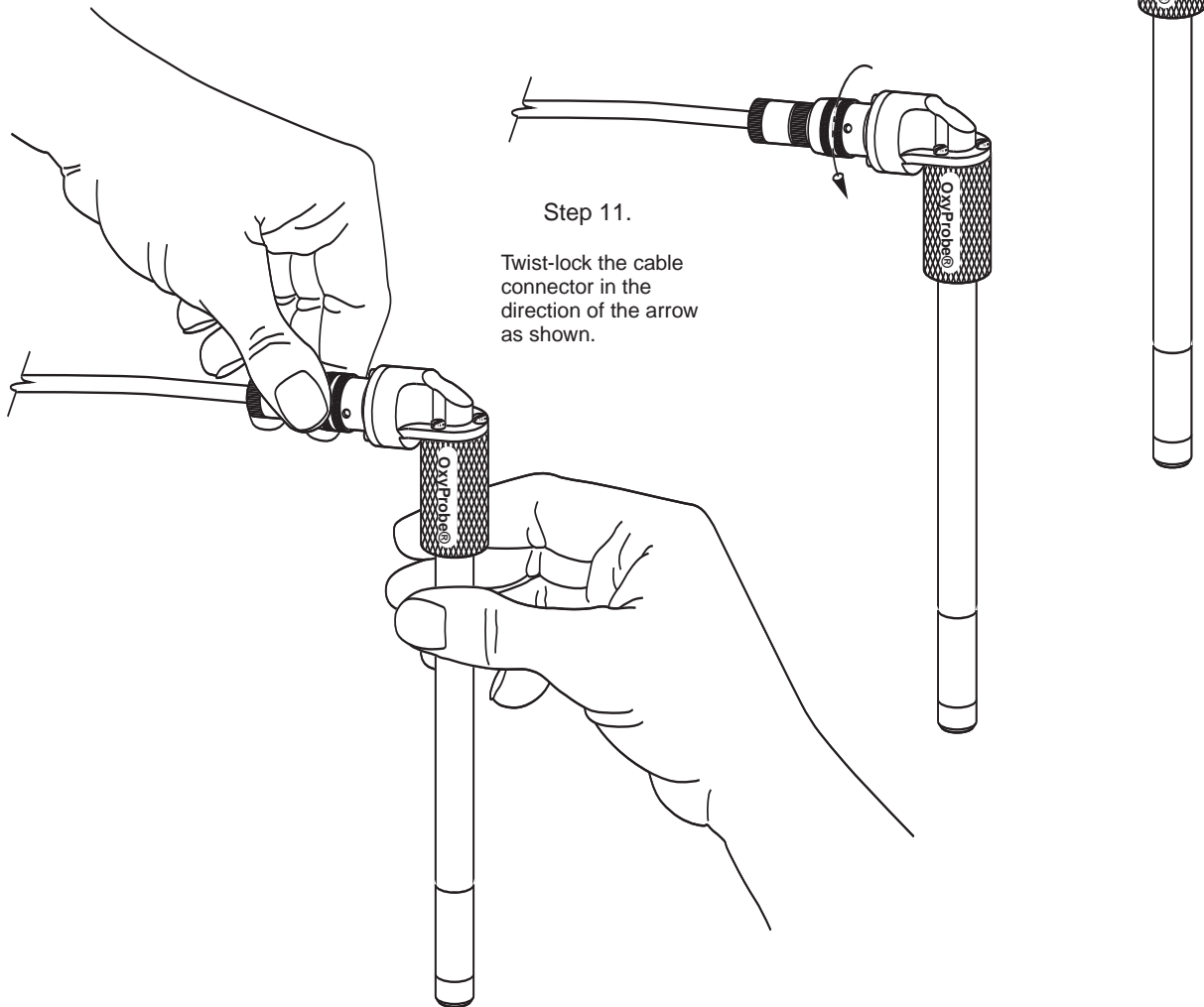
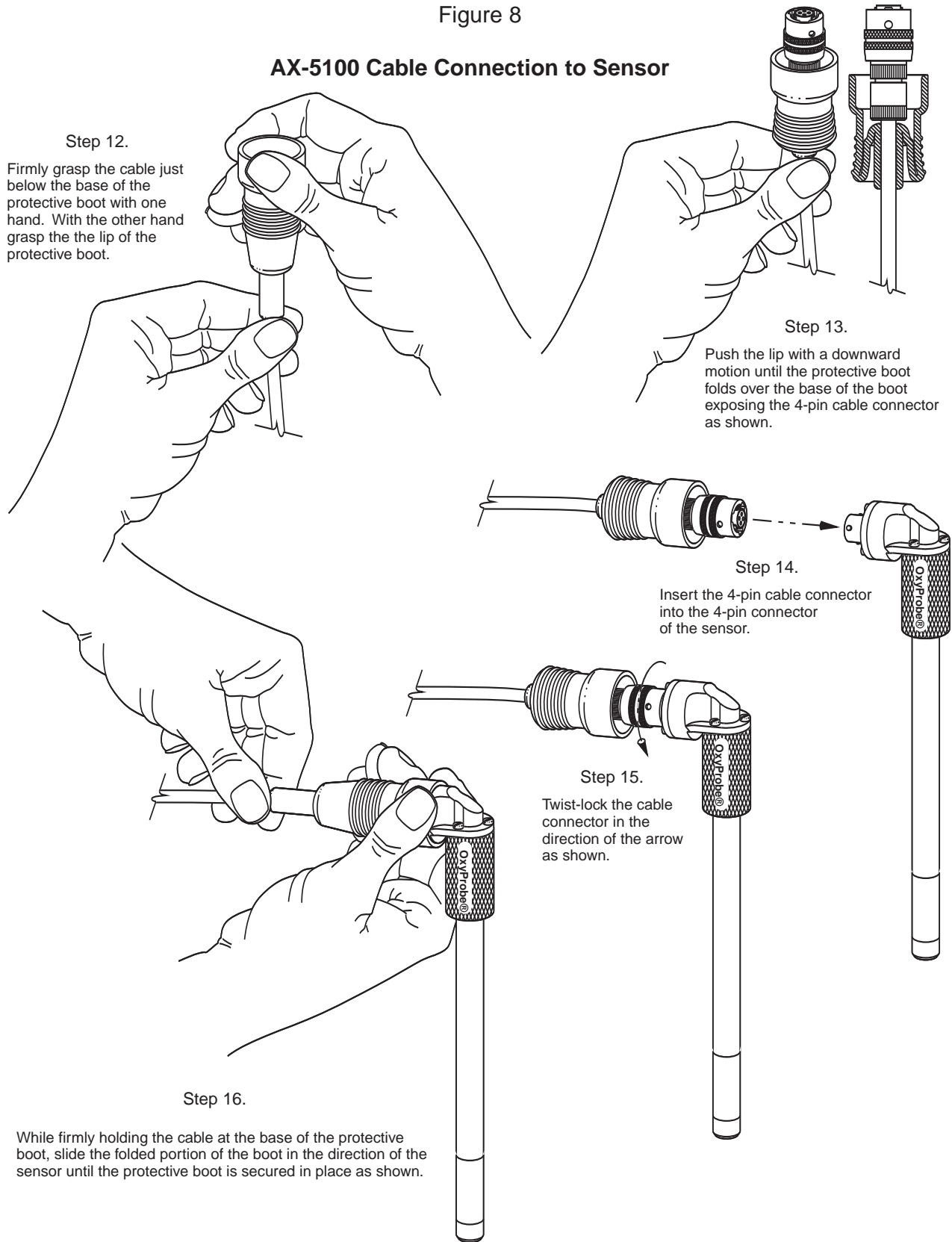



Figure 8

AX-5100 Cable Connection to Sensor



Step 12.
Firmly grasp the cable just below the base of the protective boot with one hand. With the other hand grasp the the lip of the protective boot.

Step 13.
Push the lip with a downward motion until the protective boot folds over the base of the boot exposing the 4-pin cable connector as shown.

Step 14.
Insert the 4-pin cable connector into the 4-pin connector of the sensor.

Step 15.
Twist-lock the cable connector in the direction of the arrow as shown.

Step 16.
While firmly holding the cable at the base of the protective boot, slide the folded portion of the boot in the direction of the sensor until the protective boot is secured in place as shown.



3.3 Transmitter

The transmitter to be used with OxyProbe D.O. sensors must be properly matched with the sensor. Oxygen sensors differ in regard to output current, polarization voltage, and temperature compensation technique. Therefore, the sterilizable D.O. sensor requires a transmitter with precisely defined characteristics. The transmitter specifications must be carefully examined to verify compatibility. If there is any question regarding sensor and transmitter compatibility, contact your Broadley-James representative or call 949-829-5555 for factory assistance.

3.4 Remote Recording and Control Devices

The signal circuits of all such remote instruments must be isolated from ground. If this cannot be accomplished, an isolation device must be placed between the oxygen transmitter and the remote instrument. For safety reasons the chassis of all component units must be well grounded. We recommend that the ground terminals of all ancillary instruments be connected together and taken to a known good ground point.



Chapter 4: Calibration

4.1 Calibration Comments

The dissolved oxygen measuring system should be recalibrated prior to each fermentation. If work is performed under sterile conditions, the system can be calibrated with the sensor in place after sterilization, but prior to inoculation. If the sensor is employed to monitor a fermentation process that extends over several days (or weeks) with no possibility of changing it, the electrical zero point of the sensor should be checked before insertion. The sensor should be fitted into the fermenter only if the zero point of the sensor is less than the desired measuring accuracy (i.e. 2–5% of full scale). If the zero point of the sensor is greater than this threshold consult the recommendations in Section 5.4 (Troubleshooting) for corrective action.

4.2 Transmitter Zero Point

The electrical zero point of the transmitter should first be set to correct for the non-zero background of the oxygen sensor (see the operating instructions for the host D.O. transmitter). It is critical that the sensor zero point be checked and corrective actions taken if the sensor zero current exceeds the desired measuring accuracy (i.e. 2–5% of full scale).

4.3 Sensor Zero Point

The zero current of the D.O. sensor (reading at 0% saturation) is usually negligibly small and almost identical with the transmitter zero point. Nonetheless the sensor zero point should be periodically checked as some sensor faults, which may compromise sensor performance, are detectable as an excessive zero current.

Zero point calibration may be carried out in both pure nitrogen or in water saturated with nitrogen. A further alternative is the use of a freshly-prepared 2% bisulfite solution.

The complete saturation of water with nitrogen takes approximately 30 minutes. Calibration with pure nitrogen gas is faster and more reliable. The zero point can be read after 5 minutes.

4.4 Calibration: Air Calibration

Note: Zero point adjustment (Section 4.3) must precede air calibration!

Sensor calibration is usually performed using saturated air. Place the sensor in saturated air, and adjust the instrument's reading to 100% saturation or 9 ppm.

Remember, the sensor measures the partial pressure of oxygen, which is dependent upon the total pressure. Therefore, the pressure should always be noted and the pressure valve programmed into the controller.

4.5 Measurement with Temperature Compensation

The NTC thermistor incorporated within the glass tube of the anode/cathode assembly can automatically provide for temperature compensation relating to the effect of temperature on membrane permeability. This temperature measurement provides the necessary input for the algorithm calculation of the ppm readout.

4.6 Calibration: % saturation

A solution saturated with air is defined as 100% saturated. In large-size aerated fermenters the sensor is usually calibrated in place after sterilization. Calibration should be carried out under flow, aeration and pressure conditions approximating as closely as possible those conditions expected to be encountered during the required measurement period. During measurement, the temperature and pressure in the fermenter should remain constant.



TABLE 1

**Solubility of air-saturated deionized water
at 760 mm Hg**

Temp. °C	Solubility in mg O ₂ /L	Temp. °C	Solubility in mg O ₂ /L
0	14.57	20	9.06
2	13.79	22	8.71
4	13.08	24	8.39
6	12.42	26	8.09
8	11.81	28	7.81
10	11.26	30	7.55
12	10.74	32	7.30
14	10.27	34	7.07
16	9.83	36	6.84
18	9.43	38	6.63
		40	6.42

4.7 Calibration : mg O₂ / L

In determining oxygen concentration, the O₂ content of the calibrating solution must be accurately known. The values applying to pure water are known and shown in Table 1. These solubilities need only be adjusted to the prevailing barometric pressure P_B.

$$\text{Solubility}(P_B) = \text{solubility(at 760 mm Hg)} \times P_B / 760$$

This calibration is reliable only if measurements are affected by dilute aqueous solutions. In concentrated solutions the oxygen solubility must first be determined by a Winkler titration.

4.8 Replacement and Spare Parts

See Figures 13 through 15 for exploded-view drawings and itemized parts lists of the OxyProbe 12 mm sensors.

Chapter 5: Functional Check/ Maintenance/Trouble Shooting

5.1 Functional Check of Transmitter

The D.O. Simulator (Part number AM-9222) is suitable for checking the transmitter and connecting cable for proper operation.

5.2 Functional Check of D.O. Sensor

a) Place sensor in an oxygen-free atmosphere (e.g. pure nitrogen). After approximately 5 minutes the reading should drop below 2–5% of the “air value” previously set. Failing this test indicates that the zero current is too high. See Section 5.4 for troubleshooting such a problem.

b) Place sensor in air-saturated water and set transmitter reading to 100% saturation.

c) Response time: when changing from nitrogen to ambient air, 98% of the reading should be obtained within 45 to 90 seconds. If this is not the case, consult Section 5.4 for appropriate action.

5.3 Replacement of Membrane Cartridge

OxyProbe D.O. sensors are supplied with an installed membrane cartridge which has been checked for proper function at the factory. Should sensors with fitted membrane cartridges be stored for several months after delivery, the electrolyte should be renewed before use and the proper sensor operation verified by checking the sensor zero point and calibration in room air. Failure to pass these steps may indicate that a change of the membrane cartridge is in order. If the membrane fails to operate (sluggish response, mechanical damage, etc.) it must be replaced. In so doing, observe the following instructions (Refer to Figures 3 through 6):

a) Unscrew the stainless steel cartridge sleeve from sensor body and carefully pull it away from the sensor

body.

b) Use of thumb and forefinger for removal of the membrane cartridge is all that should be required. The use of tools is not recommended.

c) Rinse the anode/cathode assembly with deionized water and dry with a clean piece of tissue paper.

d) Visually inspect the surface of the silver anode to see that it is still bright and not very tarnished.

e) Check the EPDM O-ring visually for any mechanical defects such as scratches, cracks, or perforations. Replace it if necessary.

f) Fill the new membrane cartridge to within approximately 1/8” (3 mm) of the top edge of the cartridge with dissolved oxygen electrolyte solution (P/N: AS-3140-C30-0025). Gently tap the cartridge until the remaining air bubbles have been removed from the electrolyte. While holding the membrane cartridge in the upright position, slide the cartridge over the anode/cathode assembly until the cartridge sleeve engages the housing’s threads. Thread the parts together until the EPDM o-ring can no longer be seen. There should be a flush fit between the membrane cartridge sleeve and the outer body of the sensor.

g) Rinse all parts with DI water and wipe dry with a clean paper towel or tissue.

CAUTION: The D.O. electrolyte is an alkaline solution with a pH of 13. Avoid contact of electrolyte with skin, mucous membrane, or eyes. If contact occurs flush all affected areas with plenty of water. Use of eye protection and rubber gloves is recommended.

h) Perform a functional check per Section 5.2 after each membrane replacement.



5.4 Troubleshooting

A) CONDITION – Sensor is non-responsive, i.e. sensor current equals zero.

POSSIBLE CAUSES

- **Cable Interruption:**

See functional check Section 5.1. Subsequently check measuring cable for continuity using an ohmmeter.

- **Heavily contaminated or defective membrane:**

Gently clean membrane surface with a clean tissue wetted with distilled or D.I. water or replace membrane cartridge.

- **No internal electrolyte:**

Disassemble and refill with fresh electrolyte.

B) CONDITION – Zero current of sensor too high:

POSSIBLE CAUSES

- **Partial short-circuit in sensor cable:**

Disconnect cable from sensor and set the transmitter in the nA mode, the reading should be < 1.0 nA. If not, there is either a short-circuit in the sensor cable, in which case the cable must be replaced.

- **Glass tip of cathode is cracked**

Remove membrane or inspect tip of cathode under 20-40x magnification. Small cracks near the platinum wire can cause excessive nA signal. Replace cathode.

- **Partial short-circuit or moisture in interior of sensor body:**

Remove the stainless steel membrane cartridge assembly from the sensor housing. Carefully clean the anode/cathode area of the inner sensor body with ace-

tone and allow to dry. Do not allow the acetone to come in contact with the o-rings.

Connect sensor to the cable and the cable to the transmitter and set the transmitter in the nA mode. The reading should be < 1.0 nA. If not, there is either a short-circuit in the anode/cathode subassembly or in the sensor connector. The defective component must be replaced.

C) CONDITION – Excessive response time:

POSSIBLE CAUSE

- **Deposits on membrane:**

Perform a careful mechanical cleaning using moist tissue or soft cloth, or change membrane.

D) CONDITION – Reading is much too high in all measuring ranges:

POSSIBLE CAUSES

- **Interruption of temperature compensating measurement circuit:**

Remove thermistor leads (black & brown) from the transmitter and test with ohmmeter. The resistance across these leads at room temperature should be between 20 and 30 KΩ.

- **In case of large and rapid pressure changes (or total pressure above 58 psig, 4 bar) the pressure of the gas-permeable membrane against the glass body may affect the thin electrolyte film behind the membrane and consequently the sensor output current. This often generates a high and unstable current which settles down again after a matter of hours. Avoid large and rapid pressure changes, particularly after sterilization.**

Chapter 6: Effects on Oxygen Sensor Performance

6.1 Flow Dependence

With most oxygen sensors the sensor current level is smaller in a stagnant solution than in agitated ones. The consumption of oxygen by the sensor results in extraction of oxygen from the test solution in the close proximity of the cathode. The oxygen is replaced through diffusion. If the sensor current is large the solution cannot fully restore the oxygen by diffusion. This results in a sensor current weaker than would correspond to conditions in the solution. In agitated solutions the oxygen is transported to the surface membrane not only by diffusion but additionally by the flow (convection). In that case no oxygen depletion occurs at the membrane surface.

A high degree of flow dependence occurs mainly with large cathodes or thin and highly permeable membranes (i.e. where sensor current levels are large).

The problem of flow dependence is often solved by specifying a minimum flow rate.

In OxyProbe D.O. sensors, the thin Teflon membrane which determines the sensor current (i.e. the actual measuring signal) is separated from the sample solution by a relatively thick reinforced silicone membrane. This layer is highly permeable to oxygen molecules and thus acts as an oxygen reservoir. The double Teflon/silicone membrane therefore acts as an effective buffer against disturbances due to hydrodynamic flow. Combined with the OxyProbe sensor's small cathode surface area and resulting low oxygen consumption rate, the membrane configuration makes this system ideal for use in variable flow conditions or applications of extended duration.

6.2 Oxygen Partial Pressure vs. Oxygen Concentration

The sensor current depends on the oxygen partial pressure and the O₂ permeability of the membrane — but not

on the O₂ solubility in the solution of interest. Without a prior knowledge of the oxygen solubility in the solution of interest, the oxygen concentration in mg O₂ / L (C_L) cannot be determined directly with a sensor.

According to Henry's law the oxygen concentration is proportional to its partial pressure (PO₂).

$$C_L = (PO_2) (a)$$

a = solubility factor

If *a* is constant and either C_L or *a* values are known, the oxygen concentration can be determined by means of the sensor. This methodology only applies at constant temperature and with dilute aqueous solutions such as drinking water.

The solubility factor is strongly influenced not only by the temperature, but also by the composition of the solution.

Medium saturated with air	Solubility at 20°C 760 mm Hg (ppm)	% Saturation
Water	9.1 mg O ₂ / L	100%
4 mol/KCl	2.0 mg O ₂ / L	100%
50% Methanol-water	21.9 mg O ₂ / L	100%

Although the solubilities vary widely, the oxygen sensor gives the same reading in all three solutions.

This determination of the oxygen concentration is only possible with constant and known solubility factors *a*.

Solubility may be determined by a Winkler titration or the method developed by Kappeli and Fiechter.



Chapter 7:

Sensor Installation & Maintenance

7.1 Insertion of the OxyProbe D.O. Sensors

Many small scale fermentation vessels and bioreactors are fitted with a variety of compression fittings and 12 mm ports in the headplates for installation of dissolved oxygen sensors. Insert and secure the oxygen sensor into the available fitting. Typical installations are shown in Figure 9 and 10. Consult Broadley-James Corporation for additional assistance regarding the available fitting(s) in your vessel.

Carefully inspect all o-ring, grommet, or gasket seals for any physical damage or excessive wear. Replace if there is any doubt about the condition of any of the sealing devices. The cost of o-ring, grommet, or gasket replacement is usually quite small when compared to the cost of the media in the vessel.

7.2 Preventative Maintenance

The OxyProbe sensors are designed for easy maintenance. Remove the membrane cartridge sleeve and observe the condition and amount of electrolyte liquid. If dirty or the liquid level is below 1/8" (3 mm) from the top, flush with DI water and refill with fresh electrolyte.

With a 40x power scope, closely inspect the surface of

the membrane for any scratches or perforations. If found, replace the membrane cartridge.

Inspect the large silver anode. If a large portion of it is tarnished or discolored; e.g. grey, purple/grey, or black; clean with the D.O. cleaning kit (Part number AM-9389) until the silver surface is free of most discoloration.

Visually inspect the tip of the cathode with a 10x power (or better) loop for the presence of any organic/inorganic contamination/coating.

In the case of an organic deposit, clean the tip of the cathode with non-abrasive, detergent paste and a soft paper towel.

If a grease film is observed, clean with acetone. In the event of an inorganic deposit, clean by suspending the tip portion only of the cathode in 0.1M H₂SO₄ for up to 24 hours.

The cathode tip should be free of any deposit or film before being returned to service.

Consult your Broadley-James representative or call the factory at 1-800-288-2833 for more information or additional assistance.



Figure 9
Head Plate Installation
Pg 13.5 Threads

Sensor is threaded directly into the Head Plate. Retainer nut is hand tightened. Excessive tightening with tools could damage the sensor.

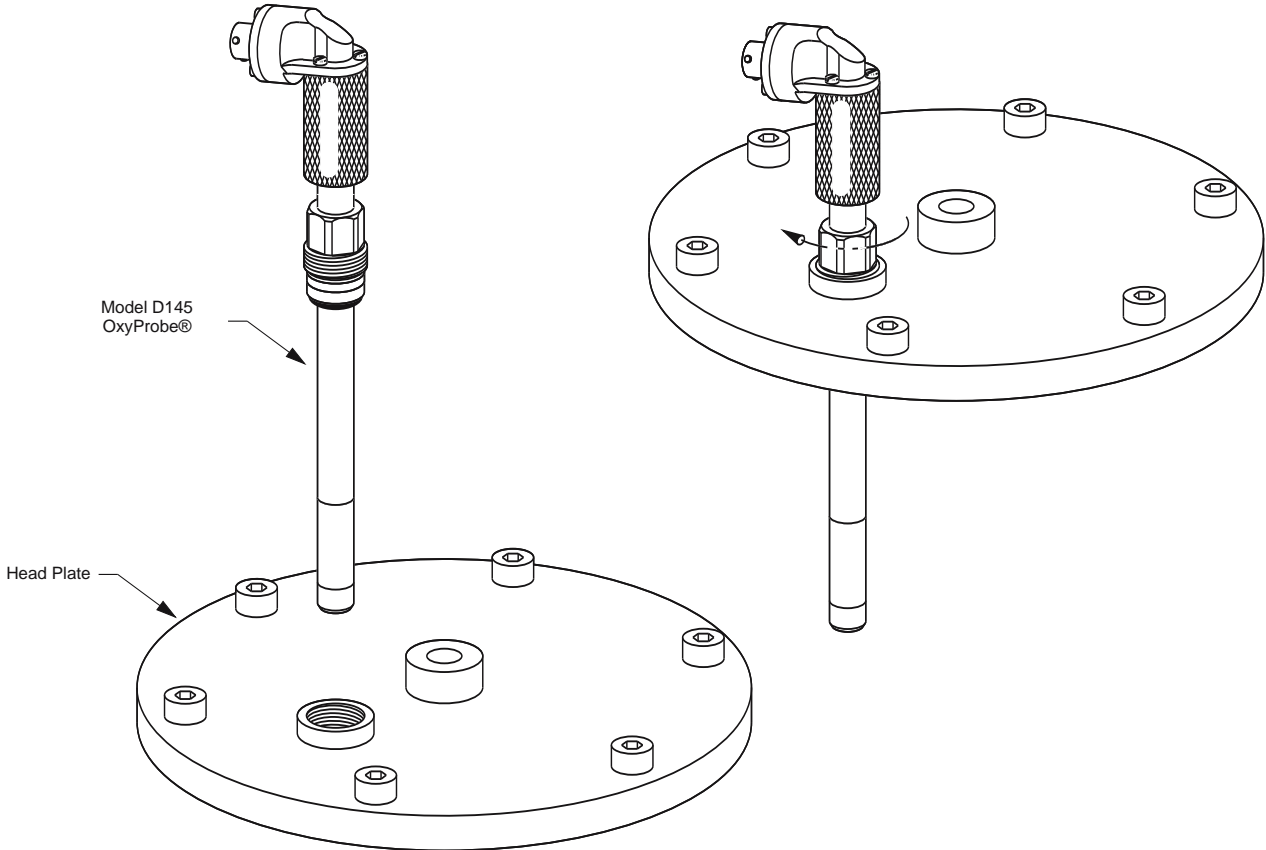



Figure 10
**Head Plate Installation
 Compression Fitting**

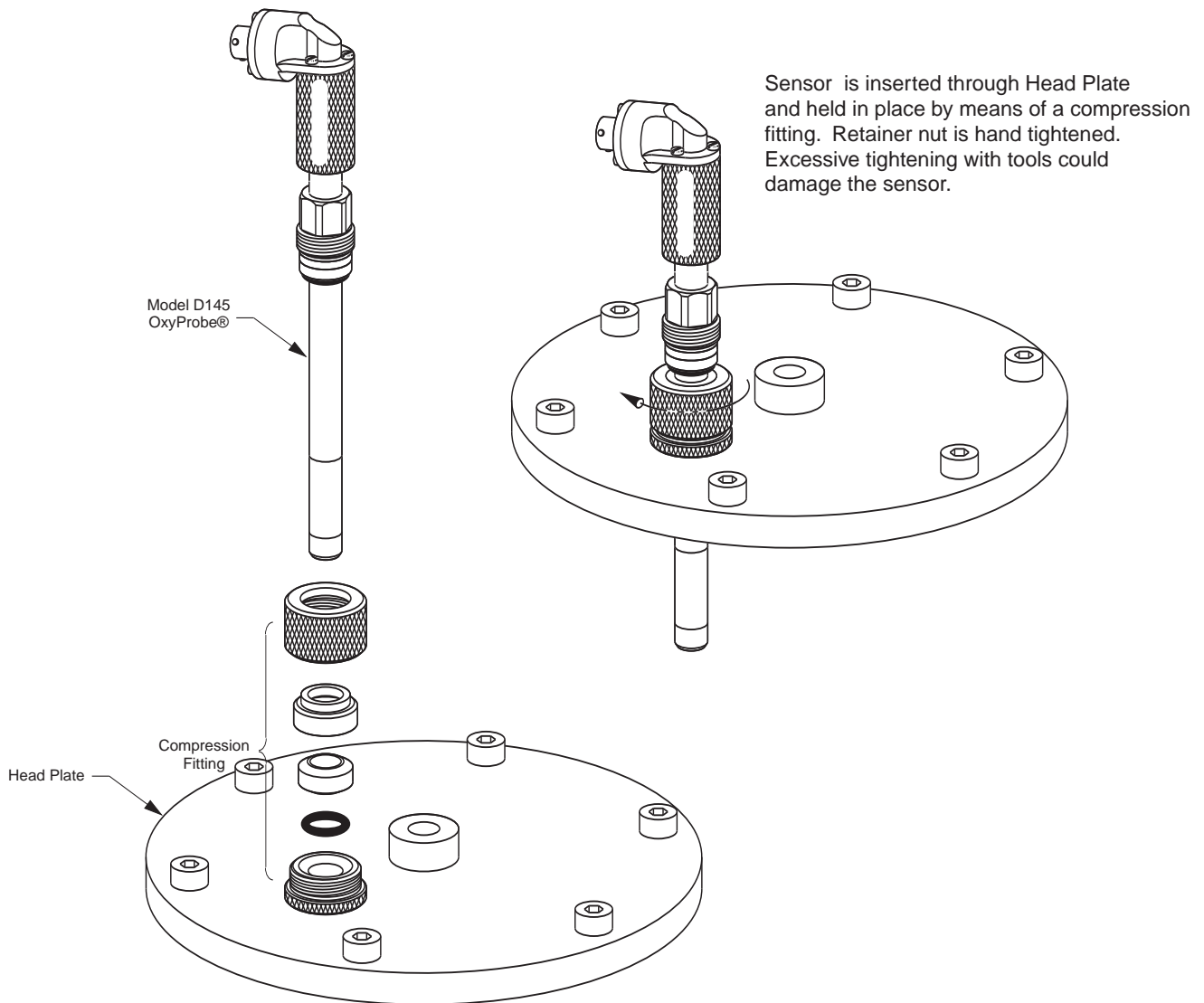
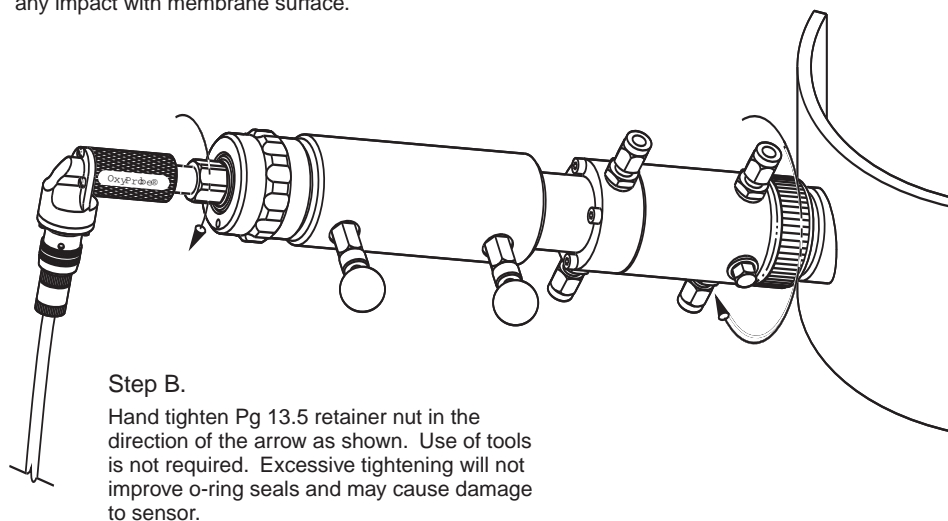
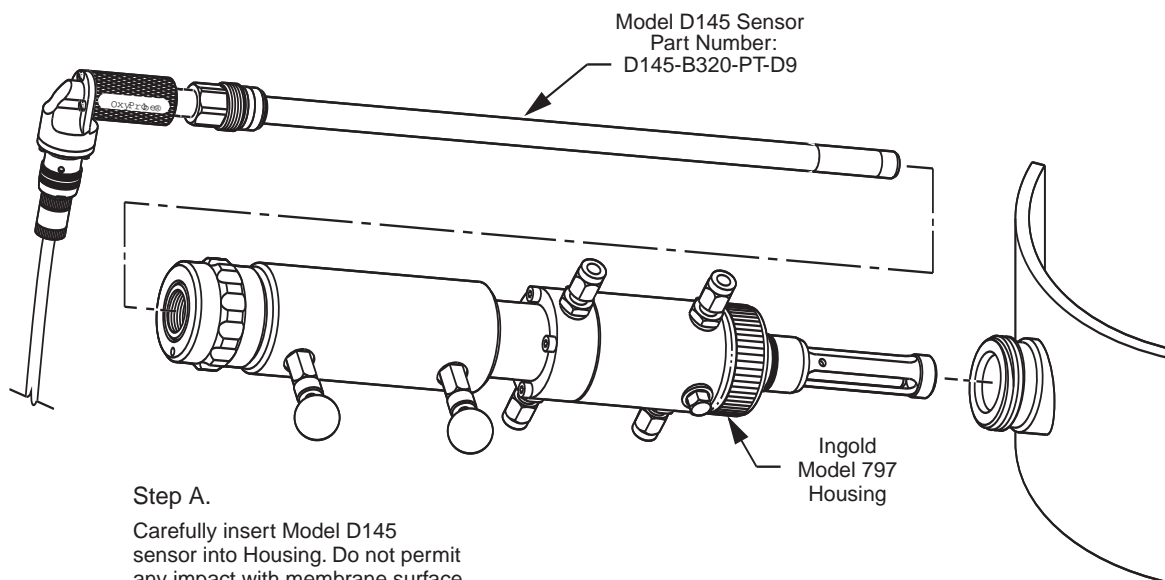

Figure 11

25 mm Side Port Installation with Ingold Retractable Model 797 Housing



Step C.
Carefully insert sensor and housing assembly into 25 mm port.
Hand tighten knurled retainer nut in the direction of the arrow as shown. Use of
tools is not required. Excessive tightening will not improve o-ring seals and may
cause damage to sensor.



Chapter 8: Replacement and Spare Parts

See next pages for an exploded-view and itemized parts list for the OxyProbe 12 mm sensor.

Figure 12

D100 & D105 OxyProbe® Sensor Assemblies

See Itemized List for Part Number & Description

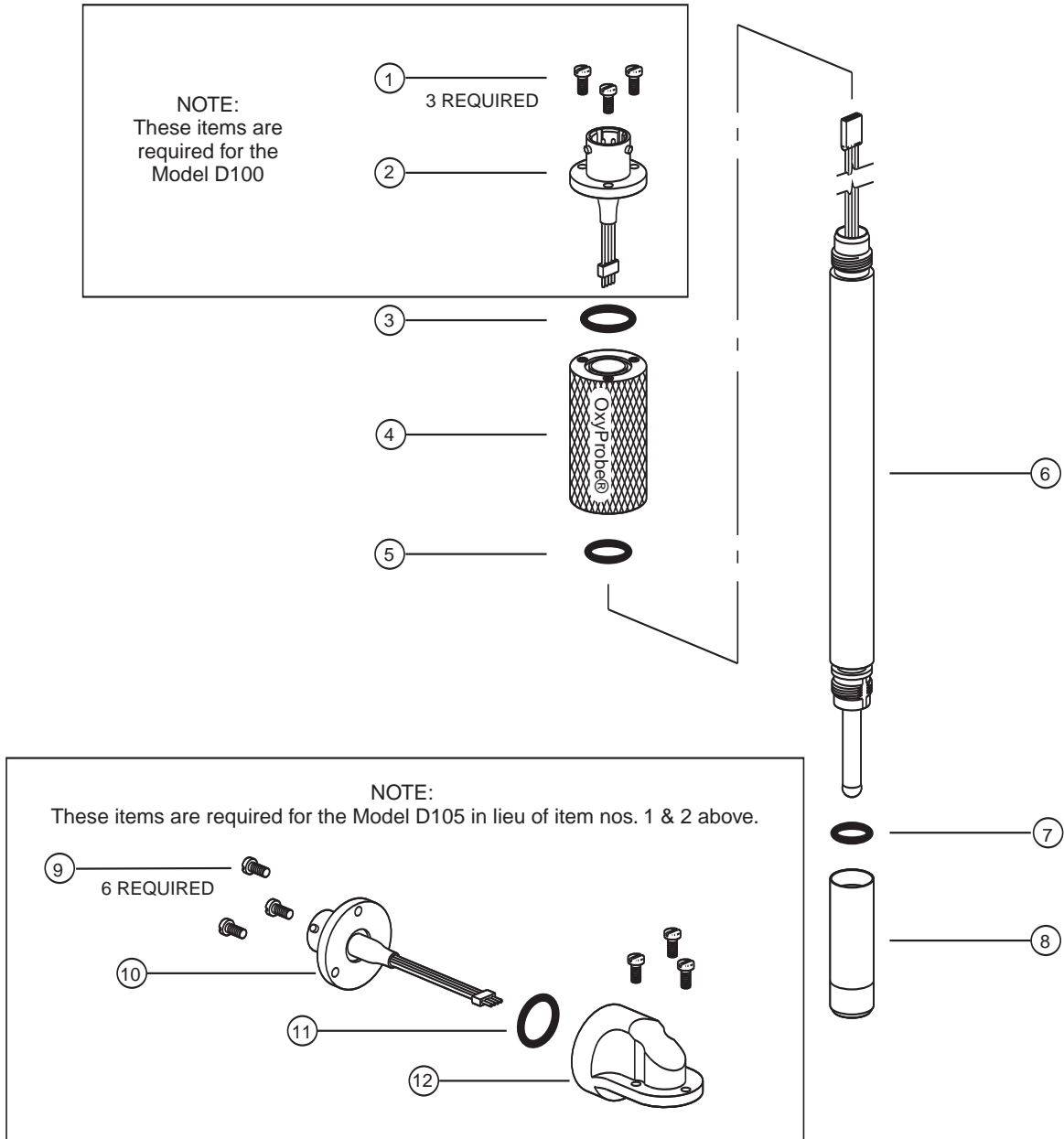



D100/D105 OxyProbe® Sensor Assembly EXPLODED VIEW, ITEMIZED PART NUMBER & DESCRIPTIONS

Item	Part Number	Description
1	AM-9230	M2.5 x 0.45 x 1/4" Stainless Steel Screw, set of 3
2	AM-9203	4-Pin Connector, glass to metal seal with ribbon/micro cable disconnect
3	AM-9316	O-ring, EPDM, size: 10.4 x 1.0 for use w/AM-9203 4-Pin Connector
4	AM-9317	Sensor Handle, 316L stainless steel
5	AM-9325	O-ring, EPDM, size: AS-012
6a	AM-9320	Cathode / Tube assembly for B = 158 mm D100/105 sensors
6b	AM-9321	Cathode / Tube assembly for B = 188 mm D100/105 sensors
6c	AM-9322	Cathode / Tube assembly for B = 258 mm D100/105 sensors
6d	AM-9323	Cathode / Tube assembly for B = 358 mm D100/105 sensors
6e	AM-9324	Cathode / Tube assembly for B = 458 mm D100/105 sensors
7	AM-9307	O-ring, EPDM, size: AS-011
8	AM-9326	Membrane Cartridge, 12 mm (Part numbers KA1201, KA1204, & KA1225 are complete replacement kits)
9	AM-9230	M2.5 x 0.45 x 1/4" Stainless Steel Screw, set of 3 (2 sets required)
10	AM-9202	4-Pin Connector, glass to metal seal with ribbon/micro cable disconnect
11	AM-9315	O-ring, EPDM, size: AS-014
12	AM-9204	Right Angle Adapter

Figure 13

D140/145 OxyProbe® Sensor Assembly

See Itemized List for Part Number & Description

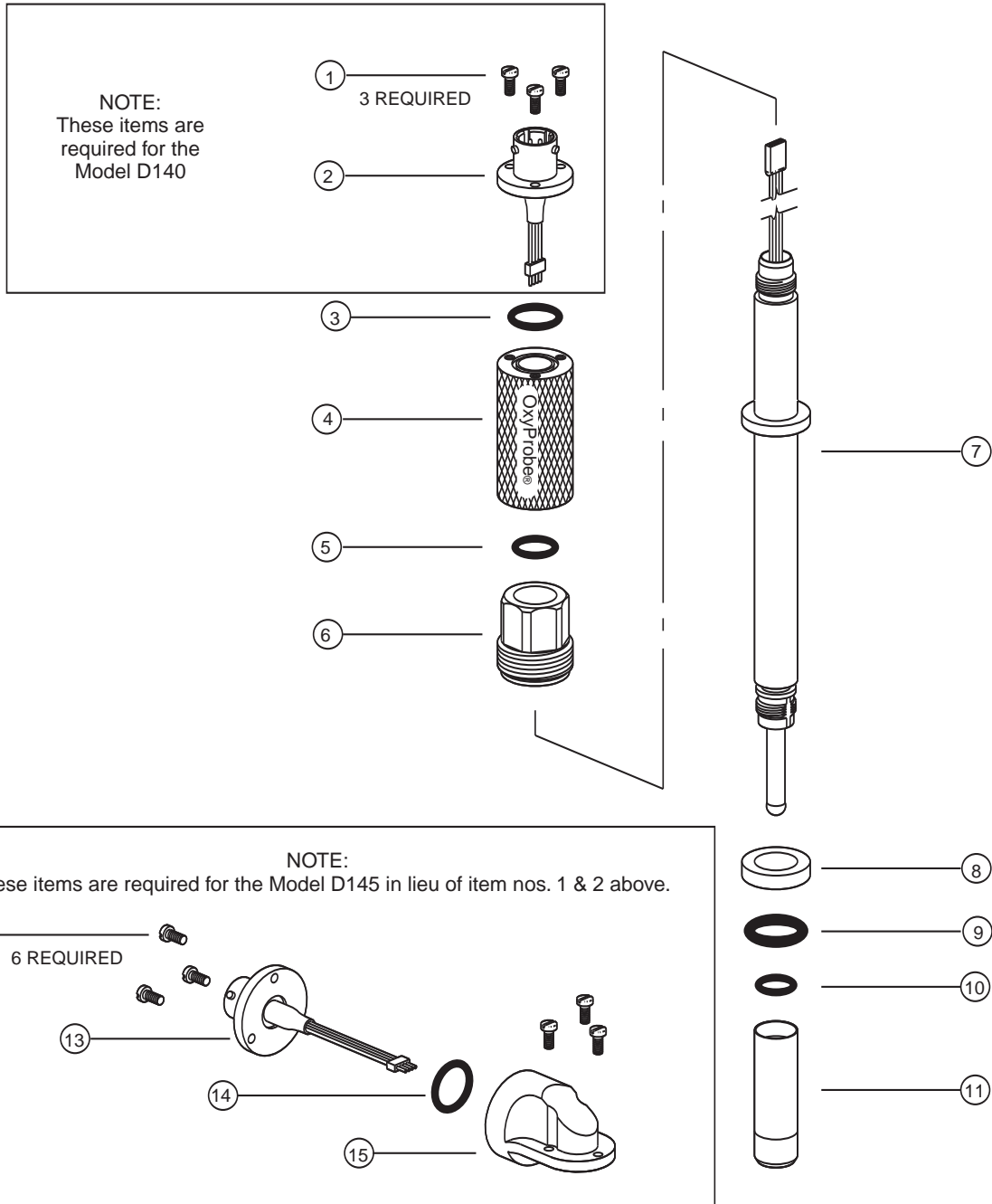



D140/D145 OxyProbe® Sensor Assembly ITEMIZED PART NUMBER & DESCRIPTIONS

Item	Part Number	Description
1	AM-9230	M2.5 x 0.45 x 1/4" Stainless Steel Screw, set of 3
2	AM-9203	4-Pin Connector, glass to metal seal with ribbon/micro cable disconnect
3	AM-9316	O-ring, EPDM, size: 10.4 x 1.0
4	AM-9317	Sensor Handle, 316L stainless steel
5	AM-9325	O-ring, EPDM, size: AS-012
6	AM-9335	Captive Nut, 316L stainless steel, Pg 13.5 thread
7a	AM-9336	Cathode / Tube assembly for B = 120 mm D140/145 sensors
7b	AM-9337	Cathode / Tube assembly for B = 150 mm D140/145 sensors
7c	AM-9338	Cathode / Tube assembly for B = 220 mm D140/145 sensors
7d	AM-9339	Cathode / Tube assembly for B = 320 mm D140/145 sensors
7e	AM-9340	Cathode / Tube assembly for B = 420 mm D140/145 sensors
8	AM-9329	Washer, Beveled, Teflon
9	AM-9328	O-ring, Viton, size: AS-111
10	AM-9307	O-ring, EPDM, size: AS-011
11	AM-9326	Membrane Cartridge, 12 mm (Part numbers KA1201, KA1204, & KA1225 are complete replacement kits)
12	AM-9230	M2.5 x 0.45 x 1/4" Stainless Steel Screw, set of 3 (2 sets required)
13	AM-9202	4-Pin Connector, glass to metal seal with ribbon/micro cable disconnect
14	AM-9315	O-ring, EPDM, size: AS-014
15	AM-9204	Right Angle Adapter



Chapter 9: Return of Materials

9.1 GENERAL

To expedite the repair and return of sensors, proper communication between the customer and the factory is important. A return material authorization (RGM number) is required. Call (949) 829-5555, (800) 288-2833 or FAX (949) 829-5560. The “Return Goods Memo” form is provided for you to copy and use in case the situation arises. The accuracy and completeness of this form will help to expedite the processing time of your materials.

9.2 WARRANTY REPAIR

The following is the procedure for returning products still under warranty.

1. Contact the factory for authorization.
2. Complete a copy of the “Return Goods Memo” form as completely and accurately as possible.
3. To verify warranty, supply the factory sales order-number or the original purchase order number.
4. Carefully package the materials and enclose the-completed copy of the “Return Goods Memo” form. If possible, pack the materials in the same manner as received.

IMPORTANT

Please see second section of the “Return Goods Memo” form. Compliance to the OSHA requirements is manda-

tory for the safety of all personnel. MSDS forms and a certification that the sensors have been disinfected or detoxified are requested.

5. Send the package prepaid to:

Broadley-James Corporation

19 Thomas

Irvine, CA 92618

Attn: Factory Repair

Mark the package:

Returned for Repair RGM No. _____

Model No. _____

9.3 NON-WARRANTY REPAIR

1. Contact the factory for authorization.
2. Fill out a copy of the “Return Goods Memo” form as completely and accurately as possible.
3. Include a purchase order number and make sure to include the name and telephone number of the right individual to be contacted should additional information be needed.
4. Perform Steps 4 and 5 of Section 9.2.

NOTE:

Consult the factory for additional information regarding service or repair.



Return of Materials Request

NOTICE TO SENDER

CUSTOMER/USER MUST SUBMIT MATERIAL SAFETY SHEET (MSDS) OR COMPLETE STREAM COMPOSITION, AND/OR LETTER CERTIFYING THE MATERIALS HAVE BEEN DISINFECTED AND/OR DETOXIFIED WHEN RETURNING ANY PRODUCT, SAMPLE OR MATERIAL THAT HAS BEEN EXPOSED TO OR USED IN AN ENVIRONMENT OR PROCESS THAT CONTAINS A HAZARDOUS MATERIAL. ANY OF THE BELOW THAT IS SUBMITTED TO BROADLEY-JAMES CORPORATION WITHOUT THE MSDS WILL BE RETURNED TO SENDER C.O.D. FOR THE SAFETY AND HEALTH OF OUR EMPLOYEES. WE THANK YOU IN ADVANCE FOR COMPLIANCE WITH THIS SUBJECT.

CUSTOMER CONTACT INFORMATION

Name: _____
Phone: _____
Ship to: _____

REASON FOR RETURN — PLEASE CHECK APPROPRIATE BOX(ES):

- | | |
|--|-------------------------------|
| <input type="checkbox"/> Wrong part received | Description of Problem: _____ |
| <input type="checkbox"/> Duplicate shipment | _____ |
| <input type="checkbox"/> Repair and calibrate | _____ |
| <input type="checkbox"/> Evaluation | _____ |
| <input type="checkbox"/> Replacement Required | _____ |
| <input type="checkbox"/> Warranty request | _____ |
| <input type="checkbox"/> Non-warranty (Customer PO# _____) | _____ |
| <input type="checkbox"/> Other (Explain) | _____ |

RETURN TO:

Broadley-James Corporation
19 Thomas, Irvine, CA 92618 USA
Tel: (949) 829-5555 (800) 288-2833 Fax: (949) 829-5560
Call for RGM NUMBER before sending (RGM #) _____





Chapter 10: Warranty

Goods and part(s) manufactured by Seller are warranted to be free from defects in workmanship and material under normal use and service for a period of two (2) years from the date of shipment by Seller. Goods and part(s) proven by Seller to be defective in workmanship and / or material shall be replaced or repaired, free of charge, F.O.B. Seller's factory provided that the goods and part(s) are returned to Seller's designated factory, transportation charges prepaid, within the two (2) years period of warranty. This warranty shall be in effect for replacement or repaired goods and part(s) for the remaining portion of the period of the two (2) year warranty. A defect in goods or part(s) of the commercial unit shall not operate to condemn such commercial unit when such goods and part(s) are capable of being renewed, repaired or replaced.

The Seller shall not be liable to the Buyer, or to any other person, for the loss or damage, directly or indirectly, arising from the use of the equipment or goods, from breach of any warranty or from any other cause. All other warranties, expressed or implied are hereby excluded.

IN CONSIDERATION OF THE STATED PURCHASE PRICE OF THE GOODS, SELLER GRANTS ONLY THE ABOVE STATED EXPRESS WARRANTY. NO OTHER WARRANTIES ARE GRANTED INCLUDING, BUT NOT LIMITED TO, EXPRESS AND IMPLIED WARRANTIES OF MERCHANTABILITY AND FITNESS FOR A PARTICULAR PURPOSE.

RETURN OF MATERIAL

Material returned for repair, whether in or out of warranty, should be shipped prepaid to:

Broadley-James Corporation
19 Thomas
Irvine, CA 92618 USA

The shipping container should be marked:

“Return for Repair”

Model: _____

RGM Nr: _____

(must be obtained from the factory prior to return)

The returned material should be accompanied by a letter of transmittal which should include the following information (make a copy of the “Return of Materials Request” found on the last page of the Manual and provide the following thereon):

1. Location type of service, and length of time of service of the device.
2. Description of the faulty operation of the device and the circumstances of the failure.
3. Name and telephone number of the person to contact if there are questions about the returned material.
4. Statement as to whether warranty or non-warranty service is requested.
5. Complete shipping instructions for return of the material.

Adherence to these procedures will expedite handling of the returned material and will prevent unnecessary additional charges for inspection and testing to determine the problem with the device.

If the material is returned for out-of-warranty repairs, a purchase order for repairs should be enclosed.