



ST925
DynaProbe®



**BROADLEY
JAMES**
CORPORATION

*Manufacturers of
pH & D.O. Sensors for
Science and Industry*

Brewing
Processes

pH Sensors

Model ST925 pH Sensors for the Brewing Process are:

Rugged

Broadley-James sensors have been used and tested for more than a decade in the pulp and paper industry under applications involving strong caustics, high temperatures and harsh industrial environments. The ST925 is a rugged, sealed sensor assembly designed for in-line applications in breweries.

Safe

The solid state reference cell features the unique IonTrap™ design for extended service life in the most severe applications. The body is molded from chemically resistant conductive Ryton (PPS) and the reference junction is porous Teflon. A built-in Pt 1000 temperature compensator is standard as is the integral solution ground connection. A separate 316L stainless steel sensor guard completely surrounds the body of the sensor and protects it from the environment and from accidental impact. This sensor is designed specifically to fit into standard 25 mm port assemblies.

Reliable

A good control system provides repeatability to the Brewmaster. It's his knowledge that produces a quality beer. The reliable sensor, however, allows him to consistently do it, over and over again, with confidence.

Main Components

Sensor

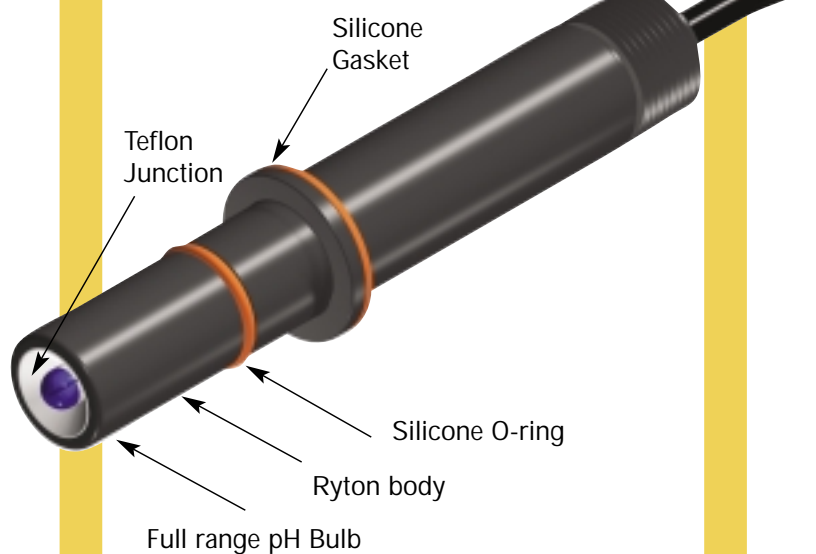

Housing

Cutaway View

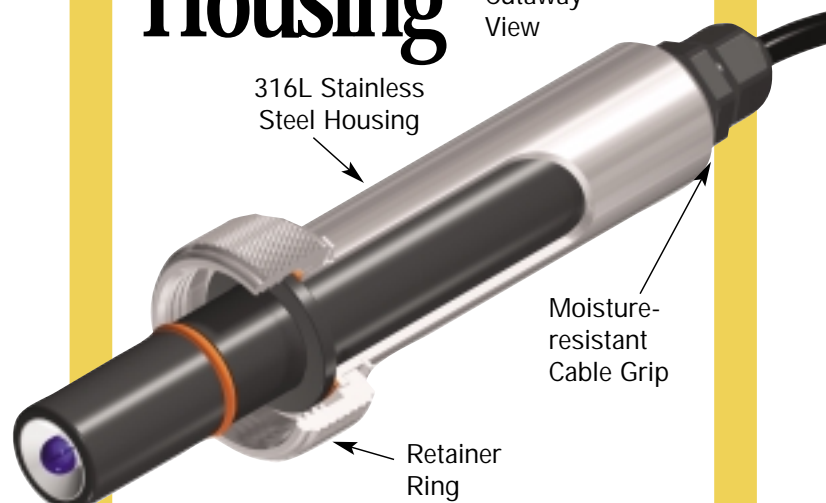

Fitting



25 mm weld-in
port fitting

Assembly

1. **Weld the fitting**, shown on left panel, into the pipe.
2. **Install the sensor**, shown on left panel, into the fitting. Thread cable through housing and its compression fitting.
3. **Secure in place** with the housing, shown on left panel.
4. **Wire to a transmitter**, as shown on right panel.

Recommended Installation

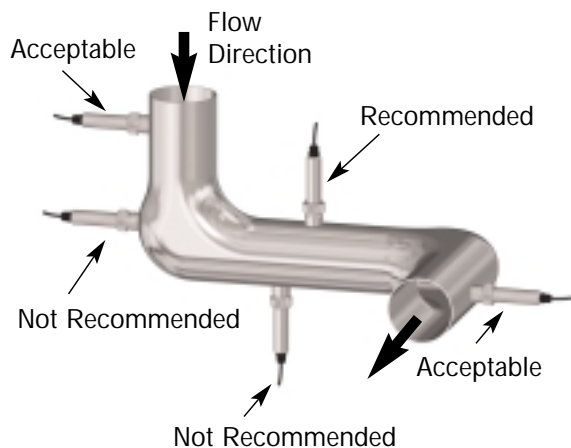
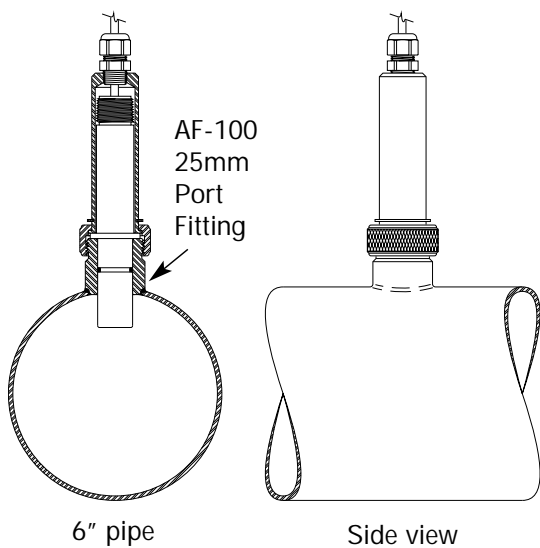

Instrumentation

Compatible with all pH transmitters.

Example below:

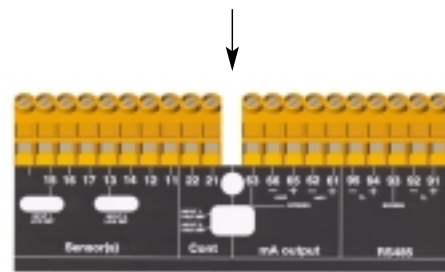

Internal terminal strip

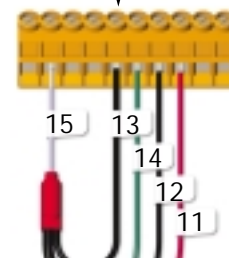

Wiring detail



Sensor supplied with standard 15' cable with ferrule connector

Specifications

pH Range. 0 - 14 pH
1-13 with minimum error

Temp Range. 0 - 130° C

Max. Pressure/Temp. 300 psig* at 120° C

Reference. Ag-AgCl

Wetted Materials Ryton, Teflon, Glass,
Silicone O-ring

Std. Cable Length . . . 15 Feet

Std. Connector Ferrules

Maximum Suggested Flow Rate

10 ft. (3 m) per second

Output Impedance

< 250 megohms at 25°C

Chemical-resistant Wetted Materials

These high quality sensors are constructed of corrosion-resistant wetted materials including Ryton®, Teflon®, Silicone and glass.

Coaxial Porous Teflon Reference Junction

The large annular junction resists fouling. Also, the sealed, patented reference electrode is highly resistant to poisoning.

Features Include

- Built-in temperature compensation
- Built-in solution ground
- Custom cable lengths available
- Choice of cable connectors

*Suitable for High Temperature Applications
Compatible with Most pH and ORP Analyzers*

*With housing E-1876-HAM-DZ



Broadley-James Corporation
19 Thomas, Irvine, California 92618
Toll-Free: 800.288.2833
Tel: 949.829.5555
Fax: 949.829.5560
E-Mail: sales@broadleyjames.com
Website: www.broadleyjames.com

Our probes can handle:

- High pressures
- Strong caustics
- Sanitation
 - CIP
 - Steam



Sensor

ST925-R33H-N15FF



Housing

E-1876-HAM-DZ

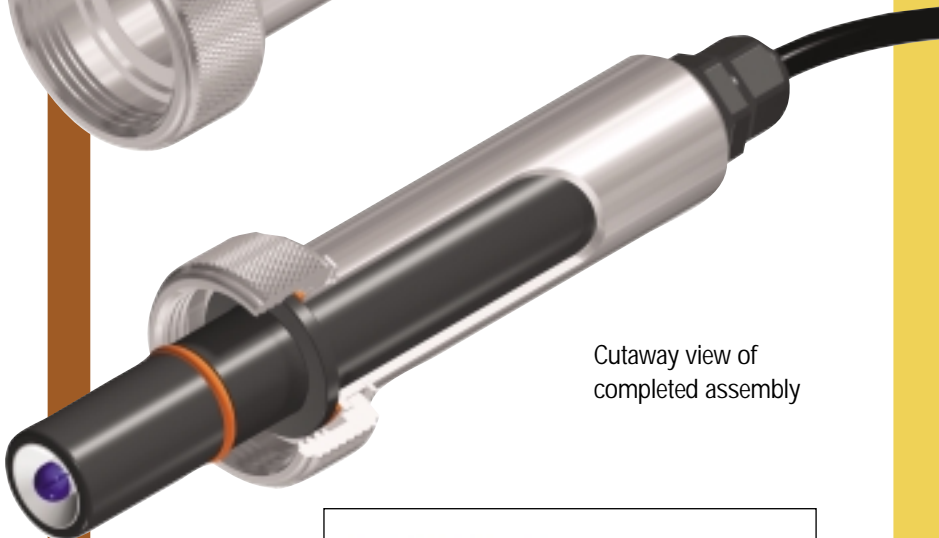

Cutaway view of completed assembly



Fitting

25 mm weld-in port fitting
AF-100-60-L040

Patented Solid State Reference

Copyright © 2001 Broadley-James Corporation
All Rights Reserved U.S. Pat.#5,147,524

L2597 02/01