

SUBMERSION

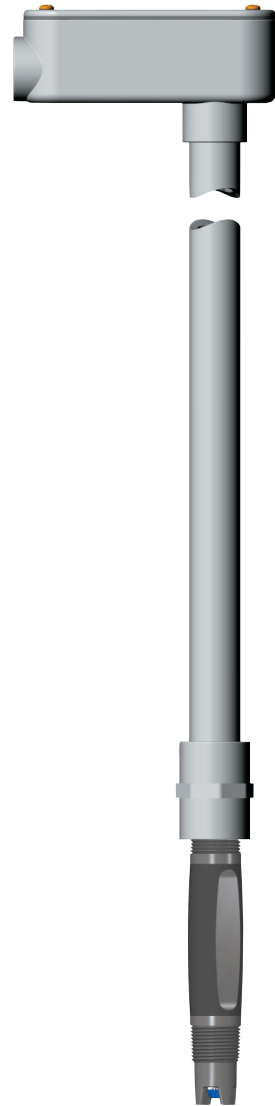

IN-LINE

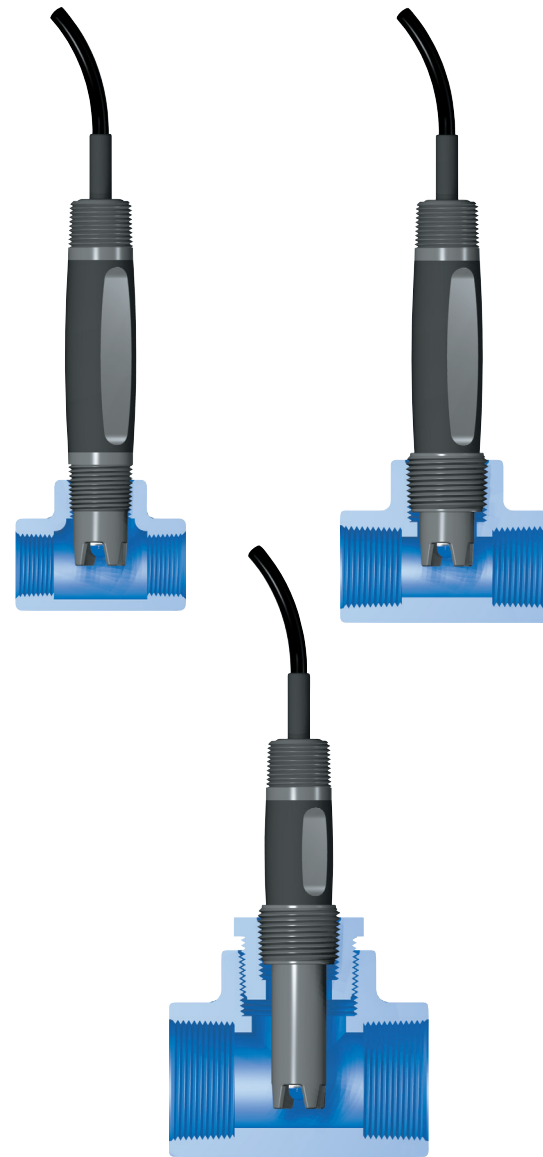

INSERTION

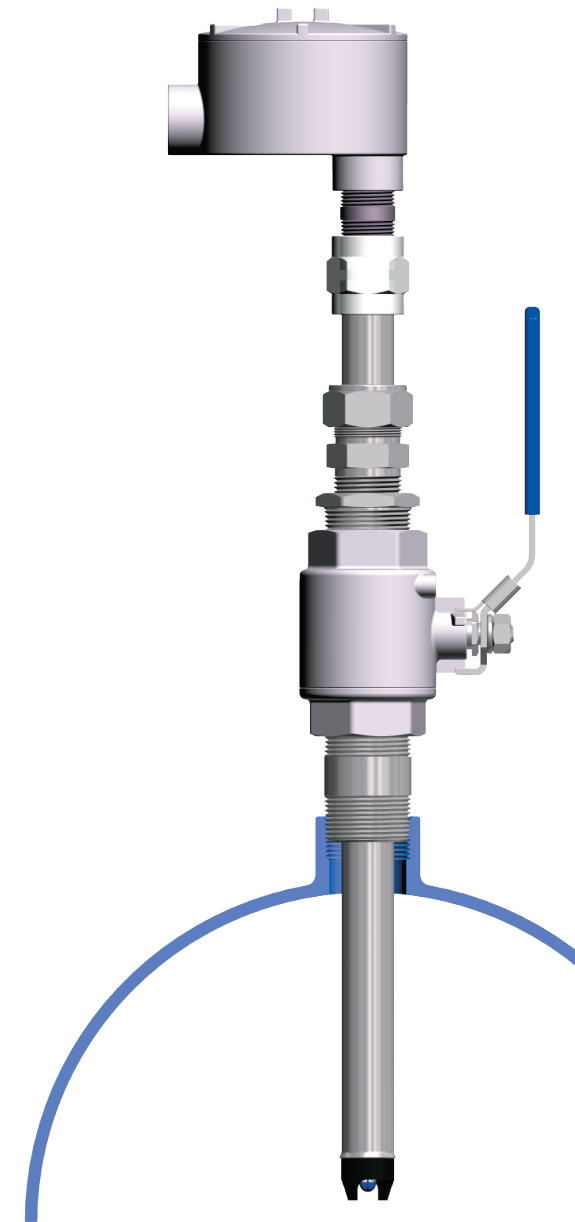

SP Series ProcessProbe®

Glass or Polymer Body Sensors with Pg13.5 Threads

The SP Series ProcessProbe sensors are available for pH and ORP measurements. The SP Series sensors are 12 mm x 120 mm with threaded Pg13.5 cap. These dimensions make them compatible with many pre-existing housings found in industrial and waste treatment applications. Like all ProcessProbes, these sensors are designed to work with Broadley-James transmitters and most other brands of existing instruments and cables.

The Double Junction Reference system used in all Broadley-James' ProcessProbes reliably prevents process contaminants from fouling the reference. Since the reference is sealed, there is no electrolyte maintenance required.

SP100 Specifications

pH Range	0 - 14 pH (2 - 12 pH with optimum accuracy)
Redox Range	± 5000mV
Temperature Range	0 to 80°C
Max. Pressure Range	4 bar, 58 psig

SP200 Specifications

pH Range	0 - 14 pH (2 - 12 pH with optimum accuracy)
Redox Range	± 5000mV
Temperature Range	-5 to 110°C
Max. Pressure Range	10 bar, 150 psig

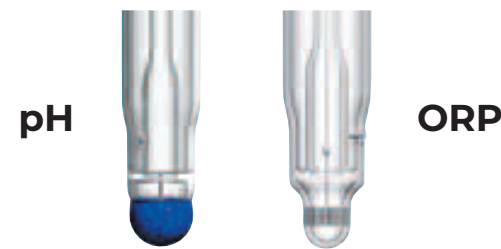

The **SP100** has a polymer body intended for use in applications up to 80°C and 4 bar (58 psig). This sensor may be a more economical alternative for low temp and low pressure industrial applications.

The **SP200** has a glass body to withstand temperatures up to 110°C and pressures up to 10 bar. It utilizes the same glass found in DynaProbes electrodes. The glass formula allows for minimum sodium ion interference while retaining fast response.

Polymer Body



Glass Body



SUBMERSION

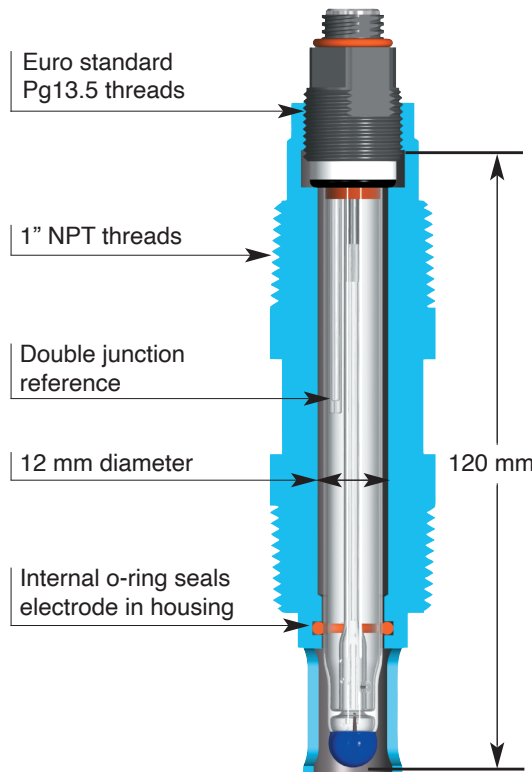
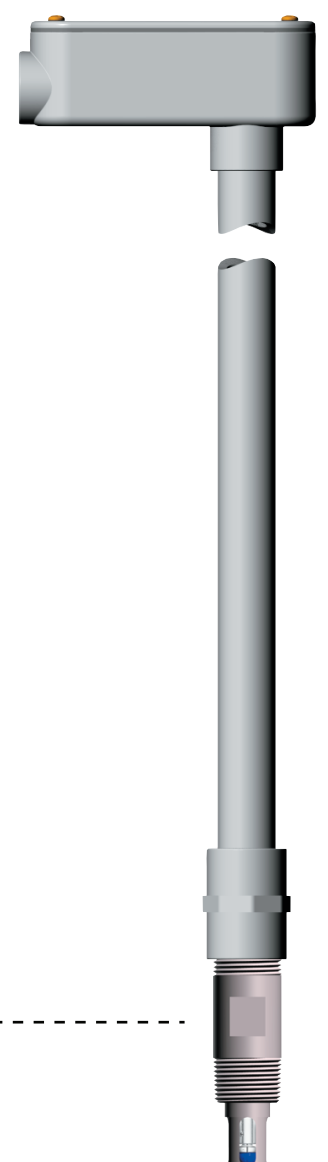

IN-LINE



1" NPT tee

S400 Series ProcessProbe®

SUBMERSION

Typical submersion assembly with S400 sensor mounted on 1" O.D. pipe with junction box

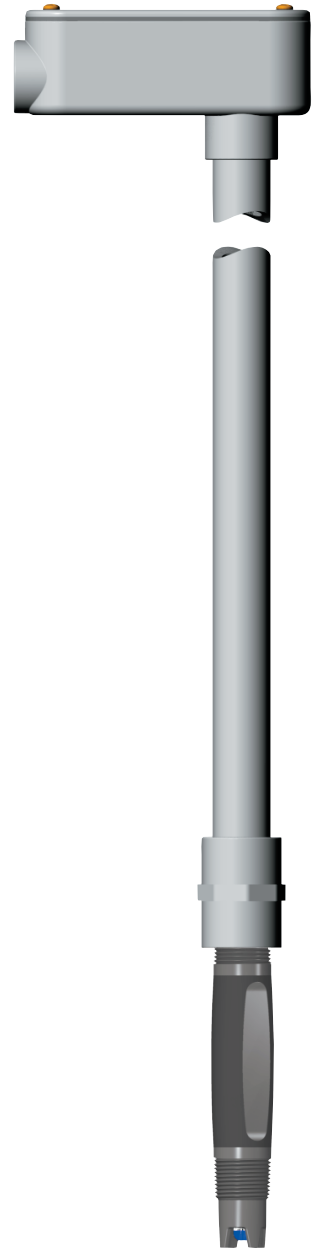

IN-LINE

Standard length with guard

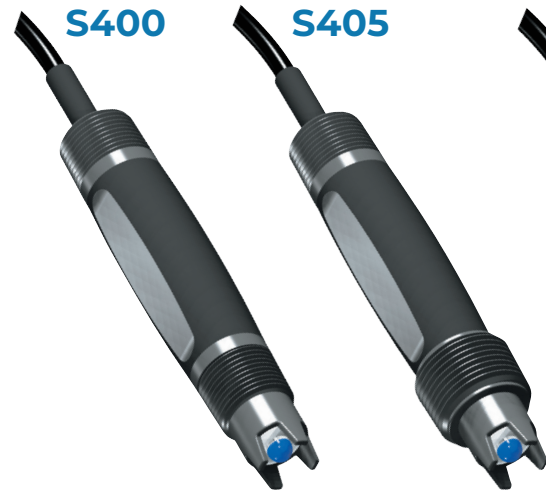

Standard length with recessed bulb



Extended length with guard

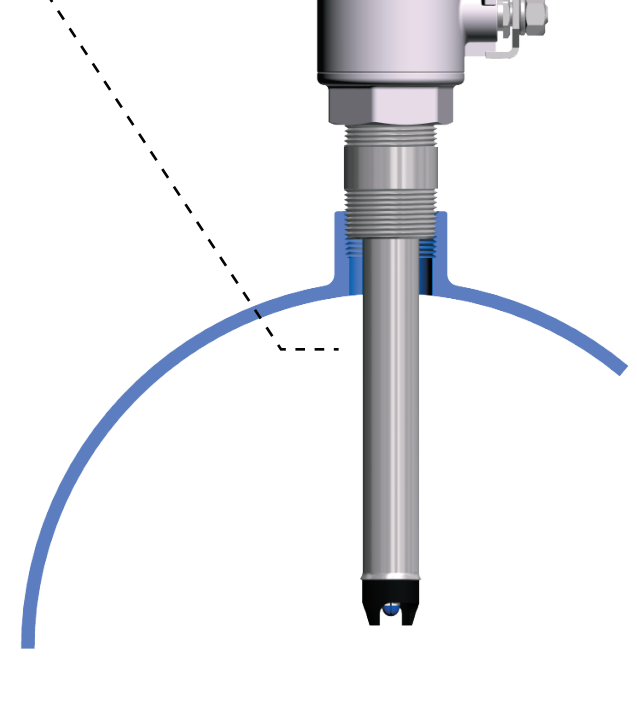
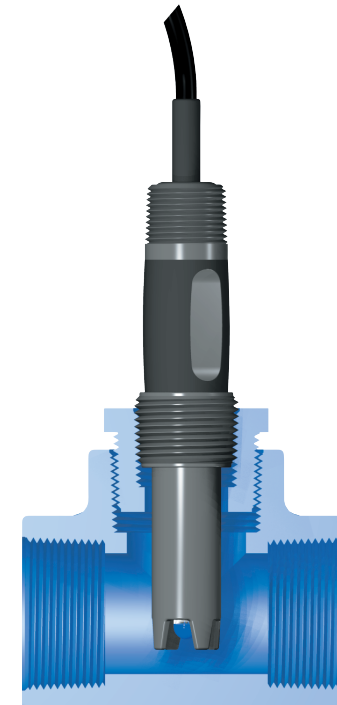

INSERTION

Replacement sensor for insertion assembly



SA877
Valve insertion assembly

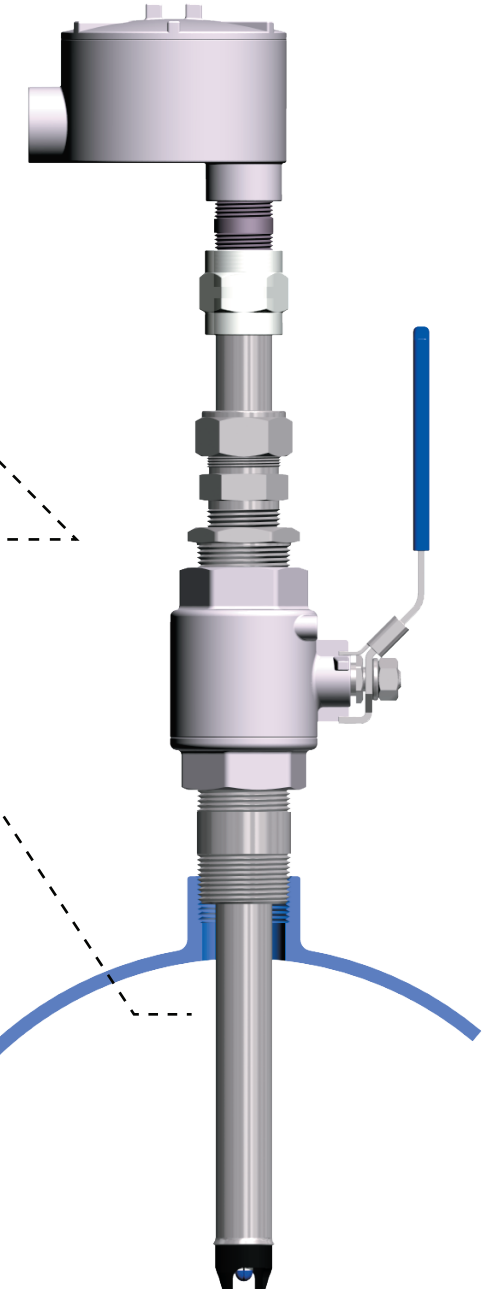

Broadley-James pH and ORP Sensors for the Process Industries

These sensors are designed for rugged service in submersion or on-line applications. The reference cell features a Double Junction design for extended service life in harsh applications. The body, with integral pipe threads, is molded from chemical-resistant Ryton (PPS) and the reference junction is porous Teflon or ceramic. Built-in temperature compensators are available. Optional sensor guard on the front of the sensor protects the sensor tip from impact. Sensor also available in ORP (Redox) version.

S400 Specifications

pH Range	0 - 14 pH
ORP Range	± 5000mV
Temperature Range	0 to 105°C
Max. Pressure Range	150 psig at 100°C
Wetted Materials	Ryton, Teflon, Glass
Std. Cable Length	10 Feet

Maximum Flow Rate:

10 ft. (3 m) per second

Output Impedance:

< 250 megohms at 25°C

Chemical-resistant Wetted Materials

These high quality sensors are constructed of corrosion-resistant wetted materials including Ryton®, Teflon® and glass.

Coaxial Porous Teflon Reference Junction

The large annular junction resists fouling. Also, the sealed, double-junction reference electrode is highly resistant to poisoning.

Options Include:

- Built-in temperature compensation
- Built-in solution ground
- Custom cable lengths
- Choice of cable connectors

Suitable for High Temperature Applications
Compatible With Most pH and ORP Analyzers



Dissolved Oxygen Measurement for the Process Industries

The ProcessProbe DO sensor has been designed for use in any process streams or wastewater application. The body is machined from CPVC with integral 3/4" NPT threads for easy installation. It also has built-in thermistor for automatic temperature compensation. The dual-layer membrane is reinforced with stainless steel mesh. This mesh helps the membrane resist damage from particulates in the process stream, extending the longevity of the sensor. The modular design of the membrane assembly makes regular maintenance simple and fast.

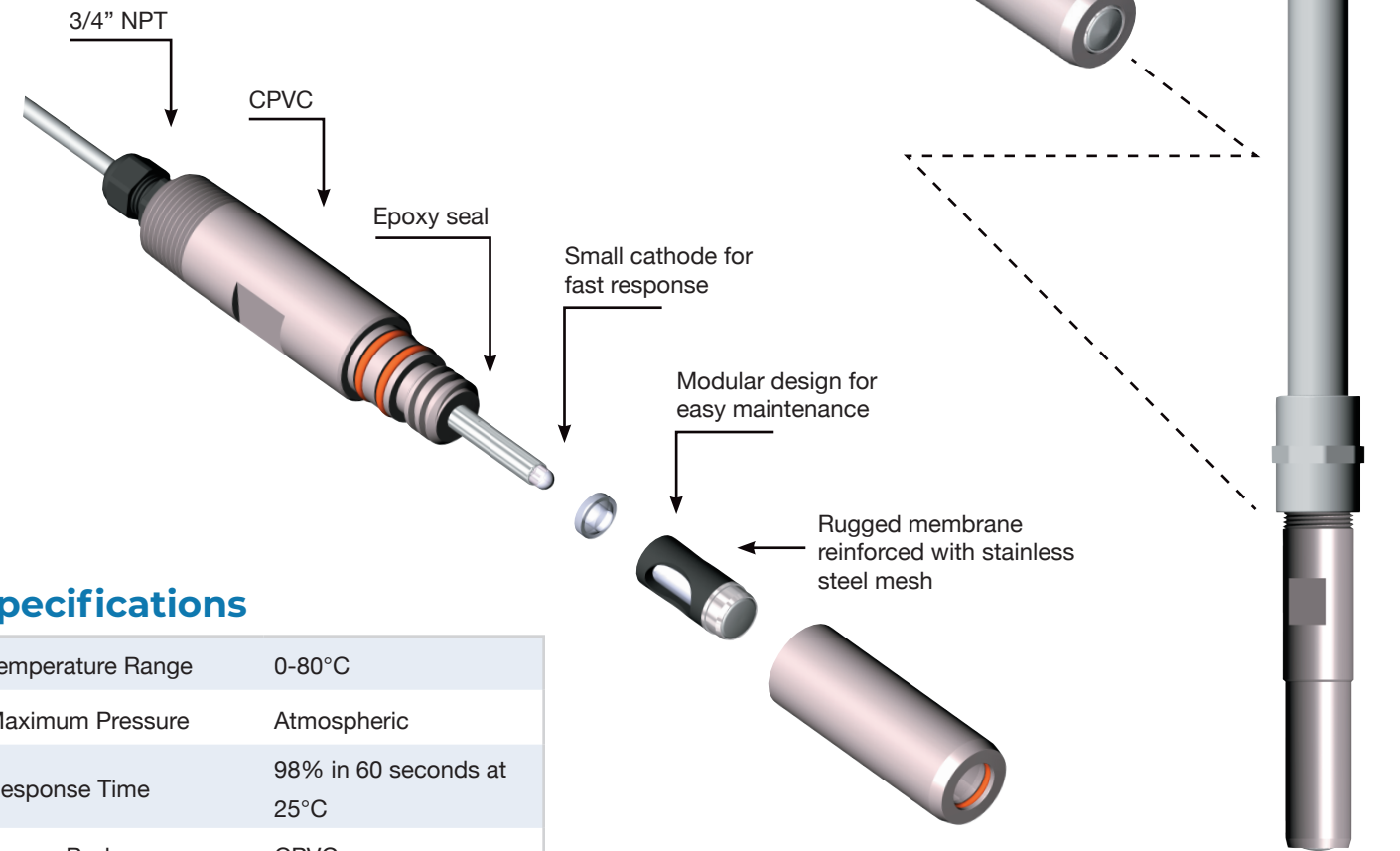

Specifications

Temperature Range	0-80°C
Maximum Pressure	Atmospheric
Response Time	98% in 60 seconds at 25°C
Sensor Body	CPVC
Membrane	PTFE/Silicone reinforced with stainless steel mesh
O-ring seals	Silicone rubber
Standard Cable Length	10 ft.

Options



Coaxial Teflon Junction

Designed to withstand tough industrial applications. Best overall performance with rugged dome pH bulb.



Pt Band for ORP Measurements

For use in highly alkaline processes. Best choice for use at higher pressures.



Flat pH Bulb/Self Cleaning

Designed for obstructionless contact with sample stream for self cleaning service. Features coaxial, porous Teflon junction.

DynaProbe® II pH and ORP Sensors

High Pressure and High Temperature Sensors

DynaProbes were designed to withstand the aggressive environment of pulp and paper manufacturing. The patented internal design features a solid state, reference half-cell with the unique IonTrap™ for extended sensor life in the most severe applications. Choose from the different body styles, body materials, reference materials and bulb designs to create a sensor to fit any industrial application. The three primary sensor designs are: twist lock, pipe thread, and valve retraction.

Twist Lock

Seals into the twist-lock housing adapter via dual o-rings for in-line measurements. The body is molded from chemical-resistant Ryton (PPS) and the reference junction is porous Teflon.

ST851 Series Specifications

pH Range	0 - 14 pH
ORP Range	± 5000mV
Temperature Range	0 to 120°C
Maximum Pressure	50 psig at 120°C
Standard Wetted Materials	Ryton, Teflon, Glass, Viton o-rings
Options Available	Dome bulb, Flat bulb, or High pH glass
Compatible Housings	Twist-Lock Adapter for threaded tee



Pipe Thread

These DynaProbes are designed for in-line or submersion applications. The sensor body threads directly into a tee or end of a pipe and is molded from chemical-resistant Ryton.

ST873 and ST956 Series Specifications

pH Range	0-14 pH
ORP Range	± 5000mV
Temperature Range	0 to 140°C
Maximum Pressure	150 psig at 120°C
Standard Wetted Materials	Ryton, Teflon, and Glass
Options Available	Dome bulb, Flat bulb, or High pH glass
Compatible Housings	1" NPT or 3/4" NPT fittings



These sensors are also available with a flat bulb design to allow the turbulence of the process to clean the sensor, minimizing clogging.

Valve Retraction

This sensor model is designed for use with the insertion/retraction assemblies. The sensor body, with integral bulb guard and anti-blowout restraint, is molded from chemical-resistant materials and the reference junction is porous Teflon.

ST977 Series Specifications

pH Range	0 - 14 pH
ORP Range	± 5000mV
Temperature Range	0 to 120°C
Maximum Pressure	100 psig at 90°C
Standard Wetted Materials	Ryton, Teflon, and Glass
Compatible Housings	Valve retraction assembly Insertion sensor assembly



All three designs are available with the following options:

- ORP Measurement
- Built-in Temperature Compensation
- Solution Ground
- Custom Cable Length